

FEATURES:

- Forged brass construction.
- Thermostatic valve cartridge: 18.30.082
- Shut-off cartridge: (1) 18.30.036
- Screw driver spring check valve: (2) 18.30.181
- 14.5 GPM @ 45PSI (9.5 top exit)
- Meets: ASME A112.18.1/CSA B125.1-2011

1/2" Thermostatic

**One Volume Control
Valve & Trim
Luxembourg Handle**

1.006596.V1
(1.006596.V1T Trim Only)

SIDE VIEW - INSTALLED

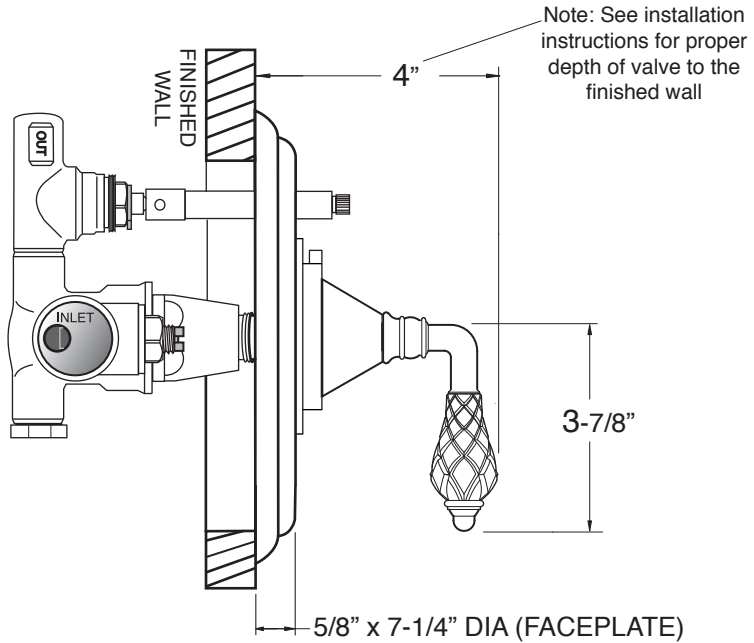

SIDE VIEW - VALVE ONLY

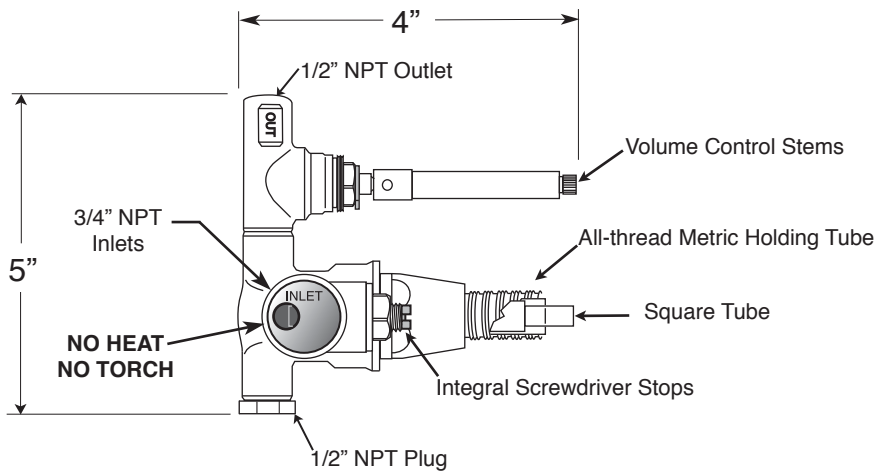

Note: Measurements are subject to change or cancellation. No responsibility is assumed for use of superseded or voided pages.