

**Series 310**

*Pressure Balance Tub and Shower Set*

**FEATURES:**

- Solid brass construction
- Valve cartridge: 18.30.893
- Diverter assembly: 18.30.894
- Screwdriver stop: 18.30.895
- Adjustable hot limit safety stop
- Reversible cartridge
- 5.0 GPM @ 60 PSI

1.313968

(1.313968T - Trim Only)

**Tribeca X Handle (39)**

Euro Style 20 pt.

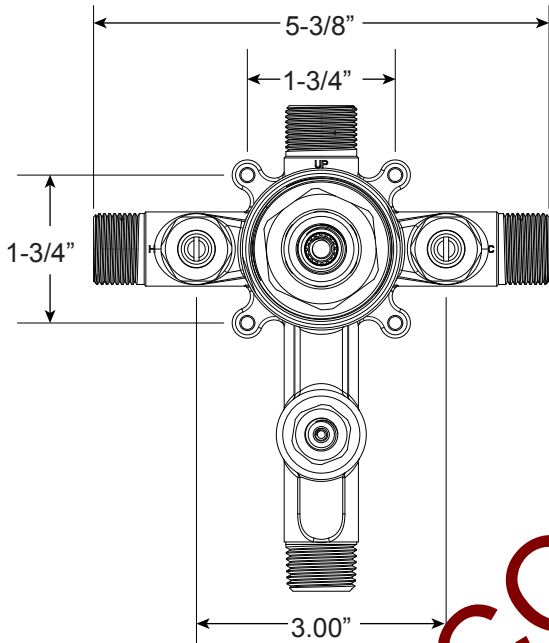

**FRONT VIEW**

Note: Stem and all-thread tube will be sent with handle trim.

**SIDE VIEW**

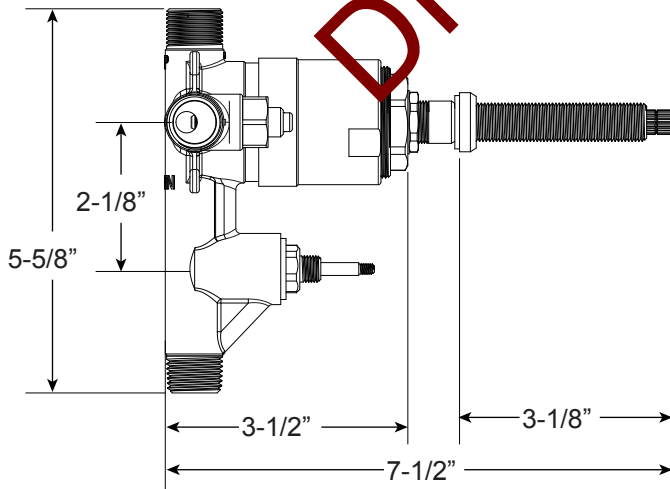

Current valve in use:  
Circa 4/2014 - present  
Contact Customer Service  
for Older Versions

For additional information on  
cartridges or extension kits,  
see 'Rough Valving' section  
in current catalog.

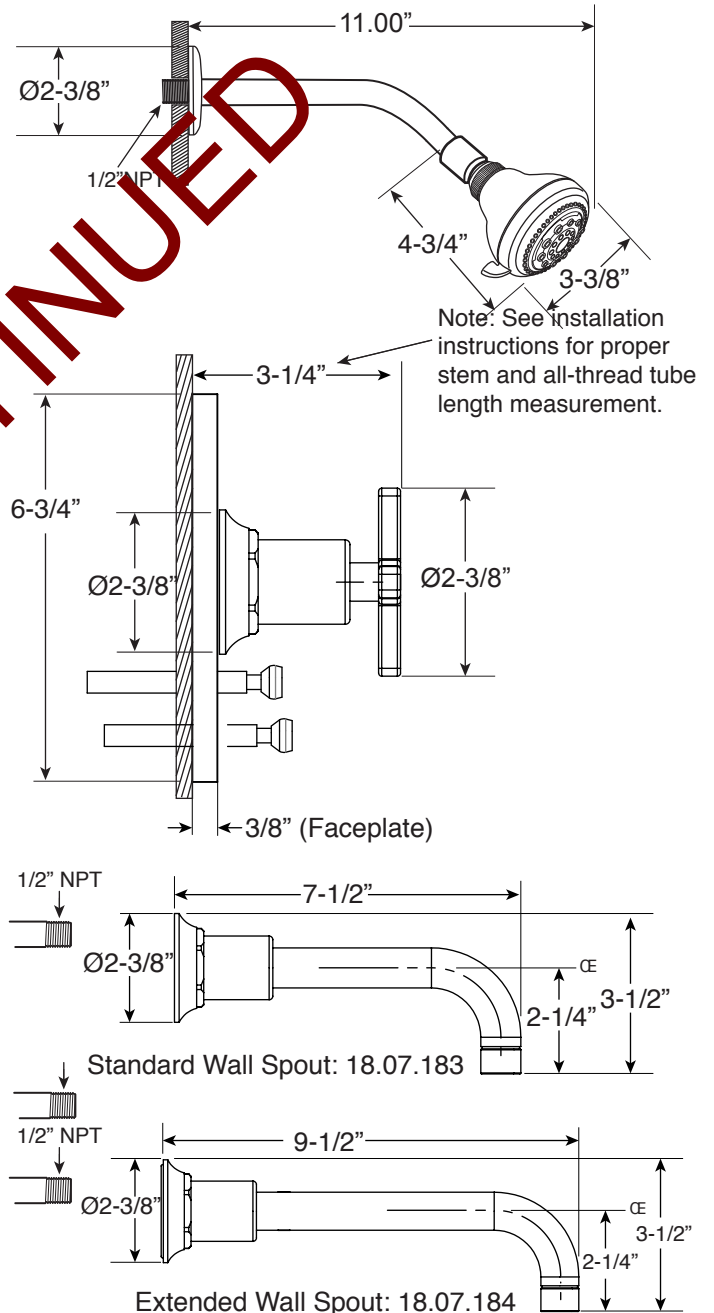

Note: Measurements are subject to change. No responsibility is assumed for use of superseded or voided pages.