

Pressure Balance Tub & Shower Set

1.808568

**Chicago Handle**

**16pt.**

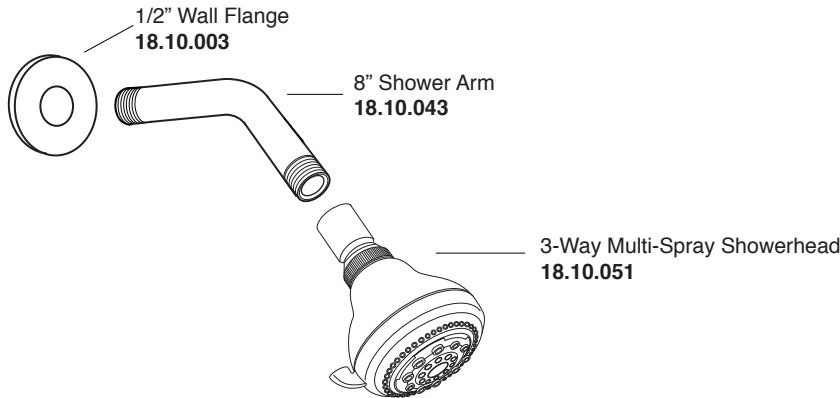

\* Current valve in use:  
Circa 4/2014 - present  
Contact Customer Service  
for Older Versions

\*\* For additional information on  
cartridges or extension kits,  
see 'Rough Valving' section  
in current catalog.

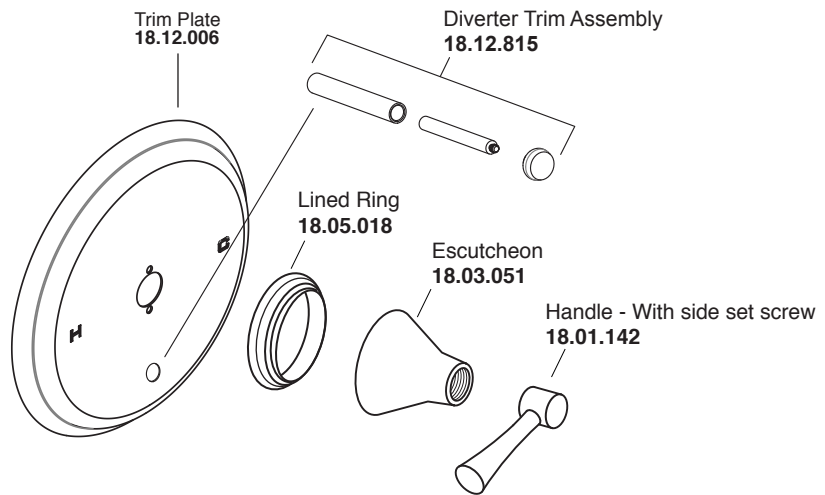

**Pressure Balance Tub & Shower Valve\***  
**18.30.062**

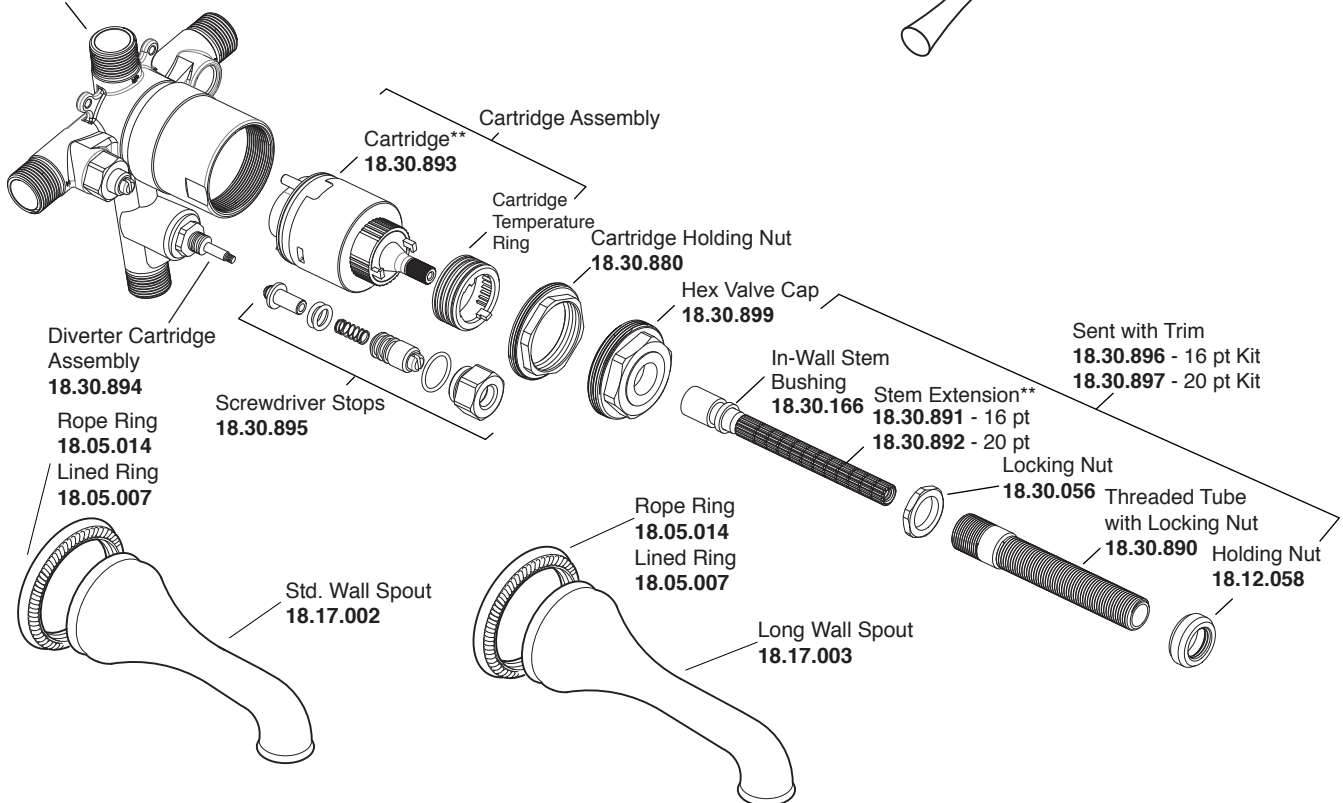

Note: Measurements are subject to cancellation. No responsibility is assumed for use of superseded or voided pages.