

**FEATURES:**

- Forged brass construction.
- Thermostatic valve cartridge: 18.30.082
- Screw driver spring check valve: (2) 18.30.181
- 14.5 GPM @ 45PSI (9.5 top exit)

Note: Separate shut-offs required to operate system.

**1/2" Thermostatic Shower  
Set without Volume Control  
with Montreal Handle**

**1.001796.V0**

**(1.001796.V0T Trim Only)**

**SIDE VIEW - INSTALLED**

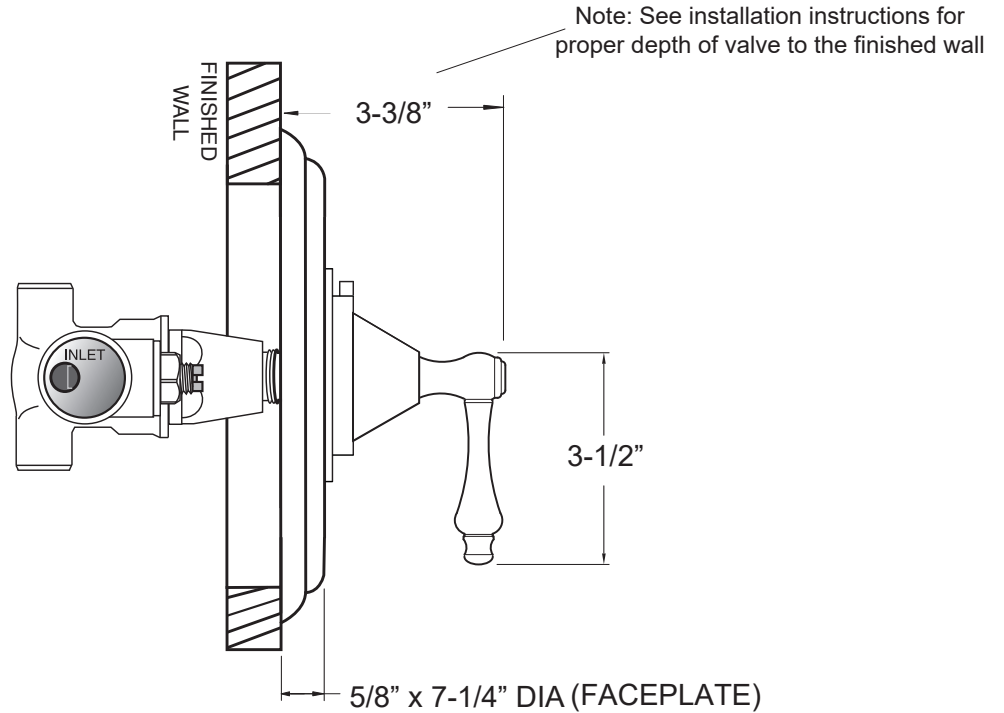

**SIDE VIEW - VALVE ONLY**

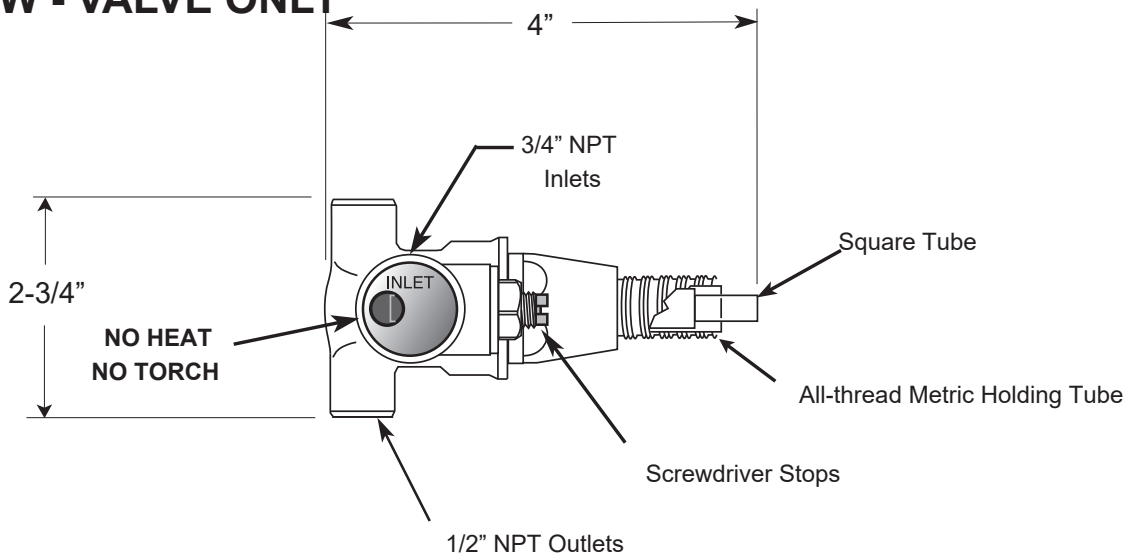

Note: Measurements are subject to change or cancellation. No responsibility is assumed for use of superseded or voided pages.