

**FEATURES:**

- All brass construction.
- Available in all finishes. Warranty varies according to finish selection.
- Thermostatic valve cartridge: 18.30.082
- Screw driver spring check valve: (2) 18.30.181
- 14.5 GPM @ 45PSI (9.5 top exit / 5.0 bottom exit)
- Meets: ASME A112.18.1-2005/CSAB125.1-2005

1/2" Thermostatic Valve and Trim

7.0148696

Finial Lever

(7.0148696T Trim Only)

Note: Separate shut-offs required to operate system

SIDE VIEW - INSTALLED

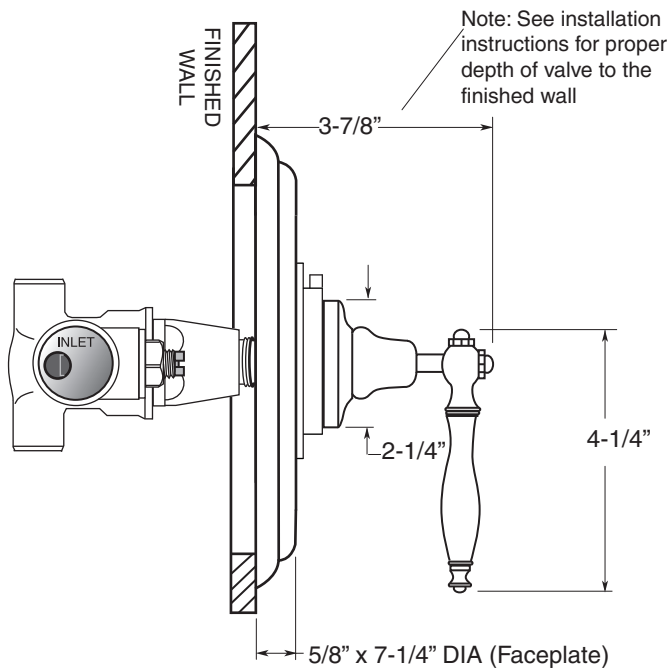

SIDE VIEW - VALVE ONLY

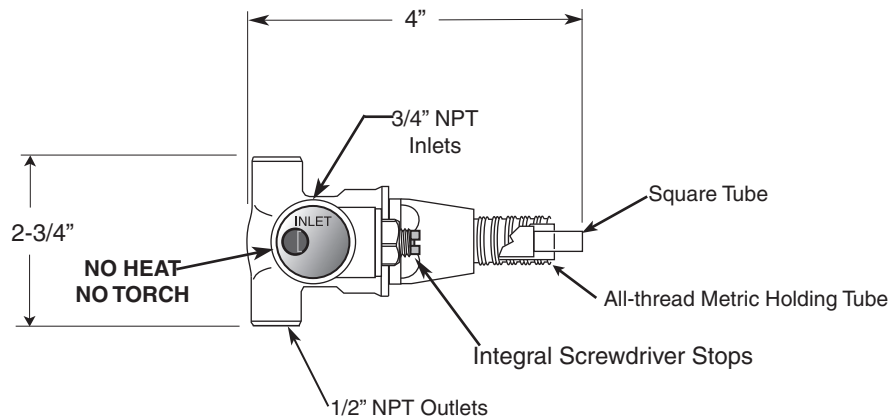

Note: Measurements are subject to change or cancellation. No responsibility is assumed for use of superseded or voided pages.