

FEATURES:

- Forged brass construction
- Valve cartridge 18.30.893
- Adjustable hot limit safety stop
- Reversible cartridge
- 5.6 GPM @ 45 PSI
- Includes 1.8 GPM Showerhead(18.10.051), arm, and flange

1.002764

(1.002764T - Trim Only)

Huntington Handle

16 pt.

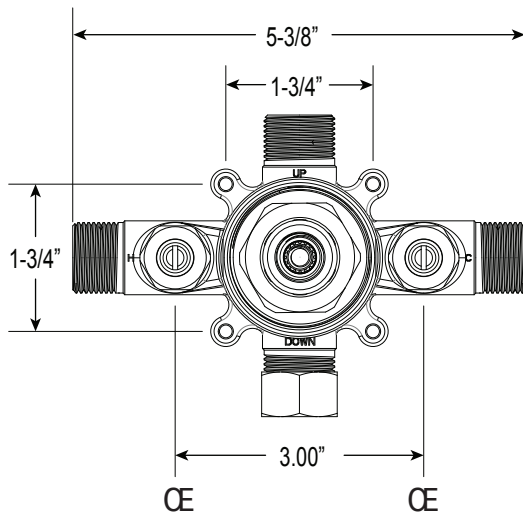

FRONT VIEW

SIDE VIEW

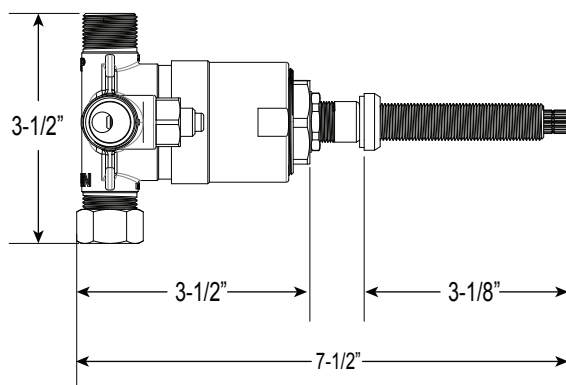

**Note: Stem and all-thread tube will be sent with handle trim.*

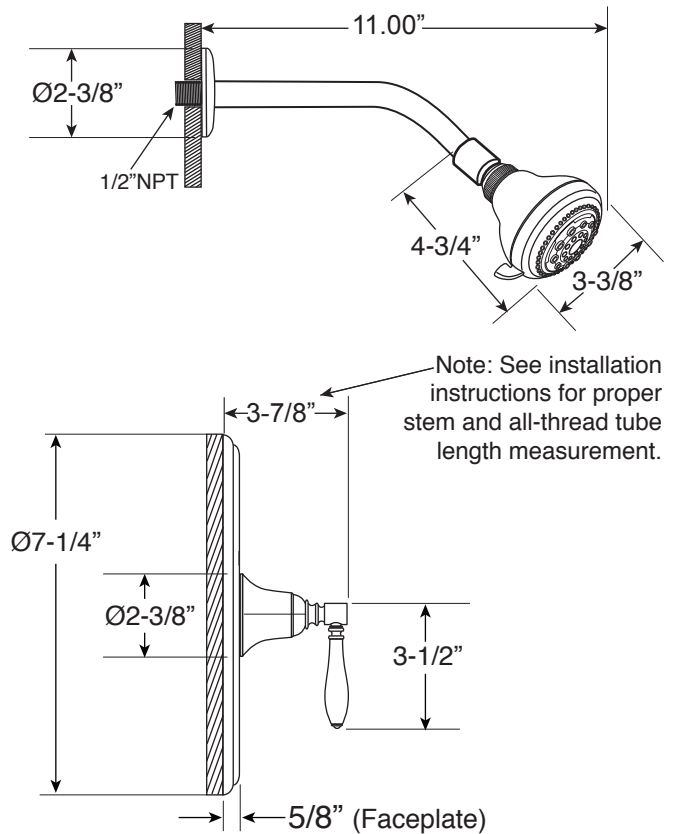

Note: See installation instructions for proper stem and all-thread tube length measurement.

* Current valve in use:
Circa 4/2014 - present
Contact Customer Service
for Older Versions

** For additional information on
cartridges or extension kits,
see 'Rough Valving' section
in current catalog.

Note: Measurements are subject to change. No responsibility is assumed for use of superseded or voided pages.