

2 Valve Shower Set

8" Spread

1.004142D

Georgian Handle

(1.004142DT Trim Only)

Features:

- Forged brass construction
- 8" Center to Center valve (18.30.008)
- 10" Center to Center valve available on request (18.30.141)
- Replacement ceramic disc cartridges:
COLD 18.30.035 / HOT 18.30.036
- Includes 1.8 GPM Showerhead (18.10.024), arm & flange

Top View

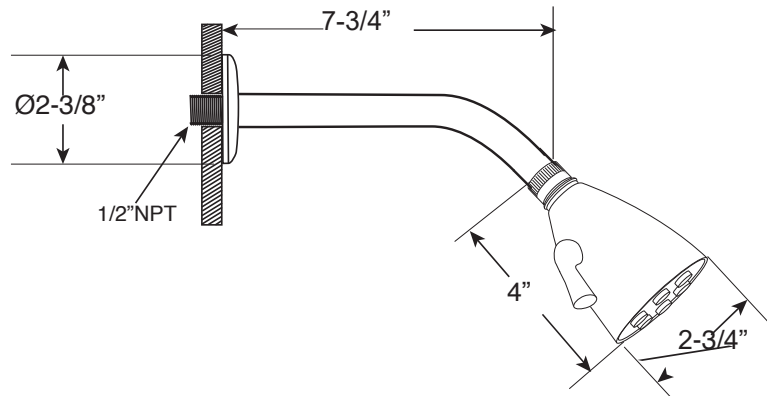
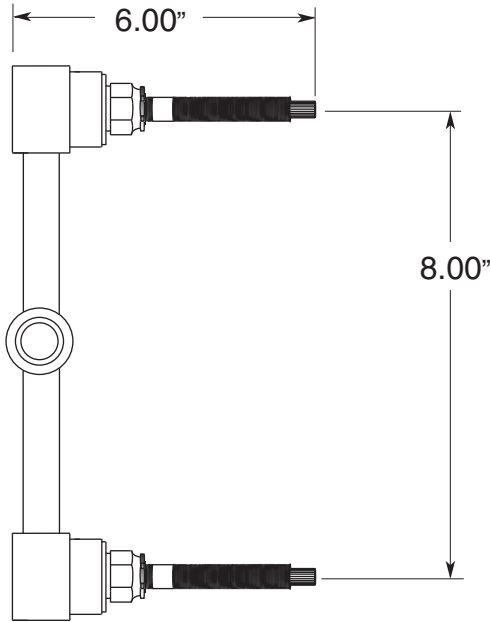

Side View

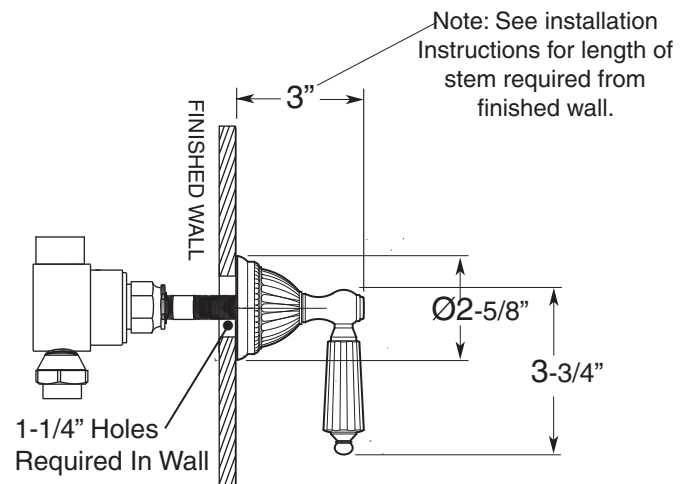
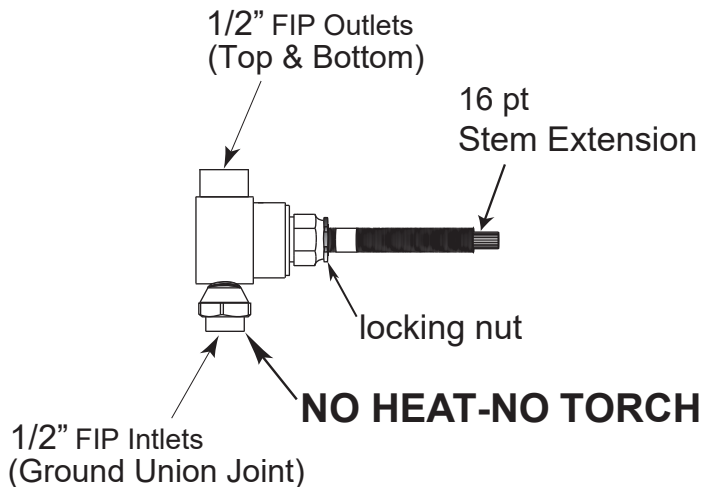

Note: Measurements are subject to change or cancellation. No responsibility is assumed for use of superseded or voided pages.