

SPECIFICATIONS

Lisse

Pressure Balance Tub & Shower

1.518368

(1.518368T - Trim Only)

Features:

- Forged brass construction
- Ceramic disk valve cartridge 18.30.865
- Adjustable hot limit safety stop
- Reversible cartridge

Cutaway View

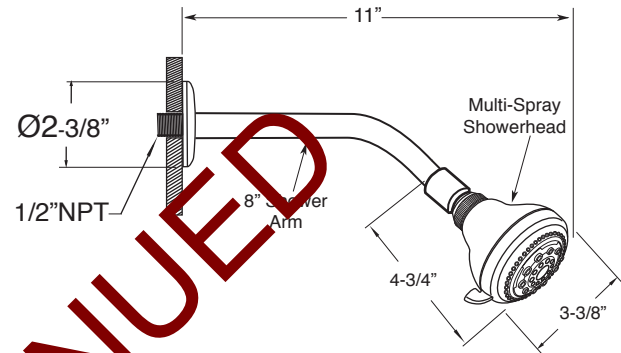
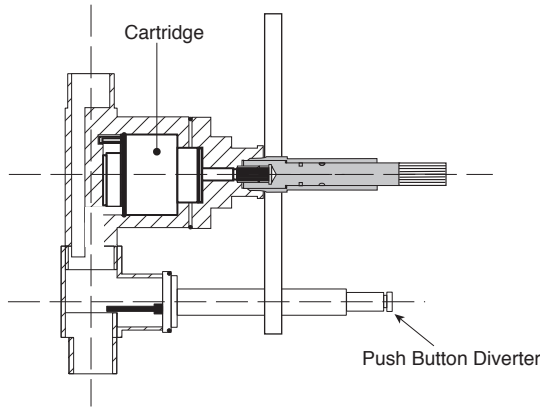

Note: See installation Instructions for length of stem required from finished wall.

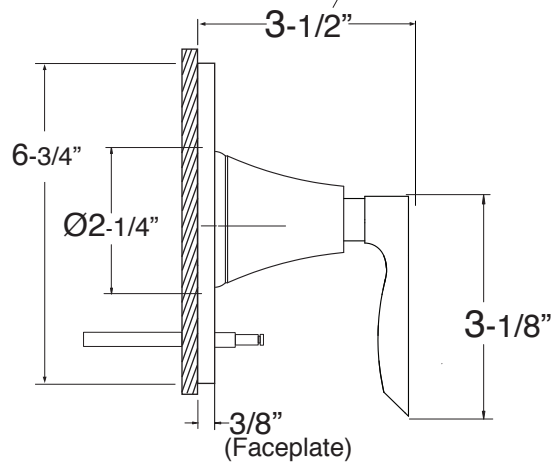

Top View

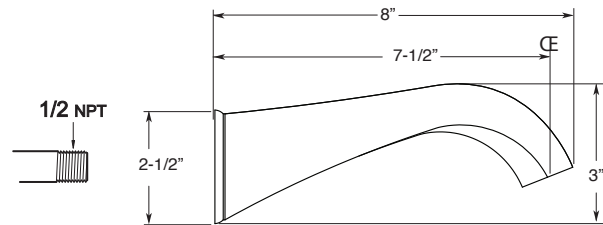
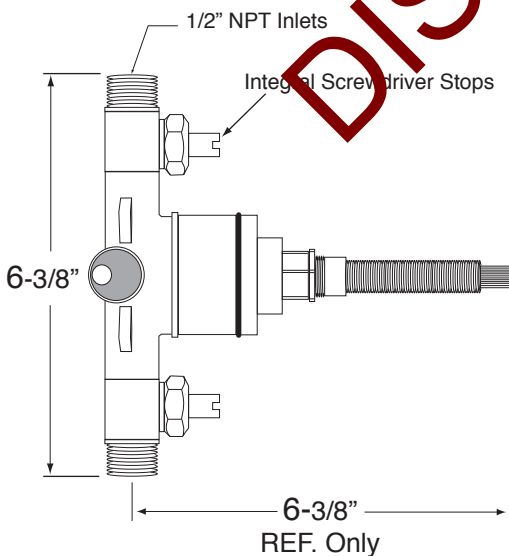

WALL SPOUT
P/N 18.17.029

Note: Measurements are subject to change or cancellation. No responsibility is assumed for use of superseded or voided pages.