

FEATURES:

- Forged brass construction.
- Thermostatic valve cartridge: 18.30.082
- Shut-off cartridge: (2) 18.30.036
- Screw driver spring check valve: (2) 18.30.181
- 14.5 GPM @ 45 PSI (9.5 top exit / 5.0 bottom exit)

**1/2" Thermostatic Shower
Set with Two Volume Controls
with Georgian Handle**

1.004196.V2

(1.004196.V2T Trim Only)

SIDE VIEW - INSTALLED

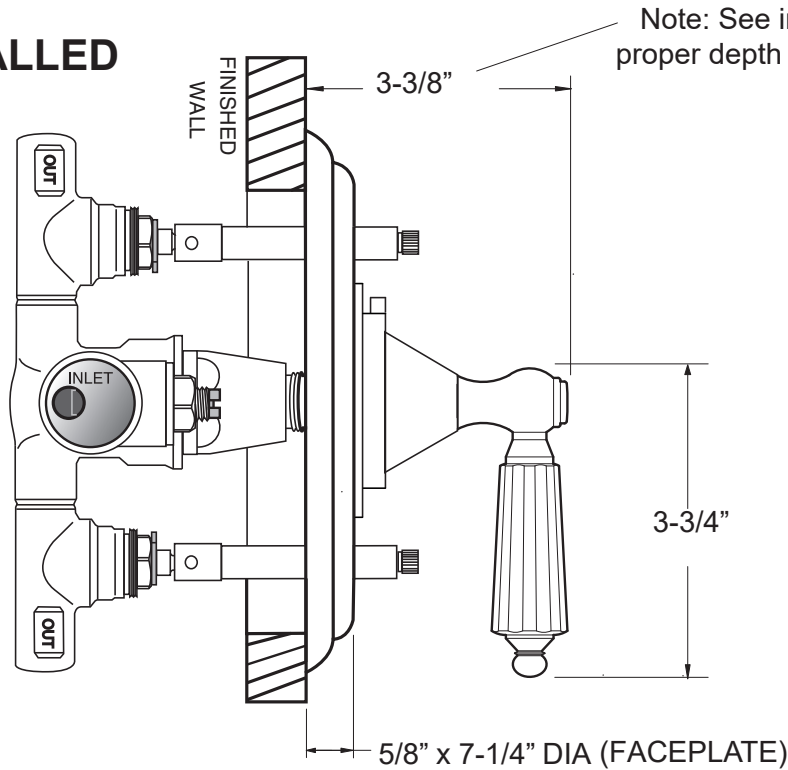

SIDE VIEW - VALVE ONLY

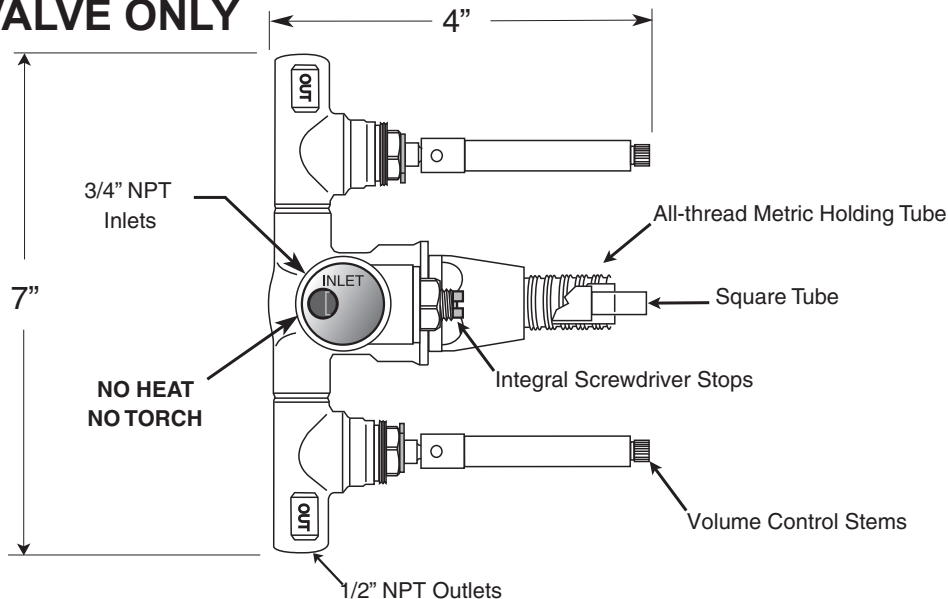

Note: Measurements are subject to change or cancellation. No responsibility is assumed for use of superseded or voided pages.