

SPECIFICATIONS
Series 3400

Pressure Balance Tub & Shower

1.345068

Ceres II Handle

(1.345068T - Trim Only)

Features:

- Forged brass construction
- Ceramic disk valve cartridge 18.30.865
- Adjustable hot limit safety stop
- Reversible cartridge
- 5.6 GPM @ 45 PSI

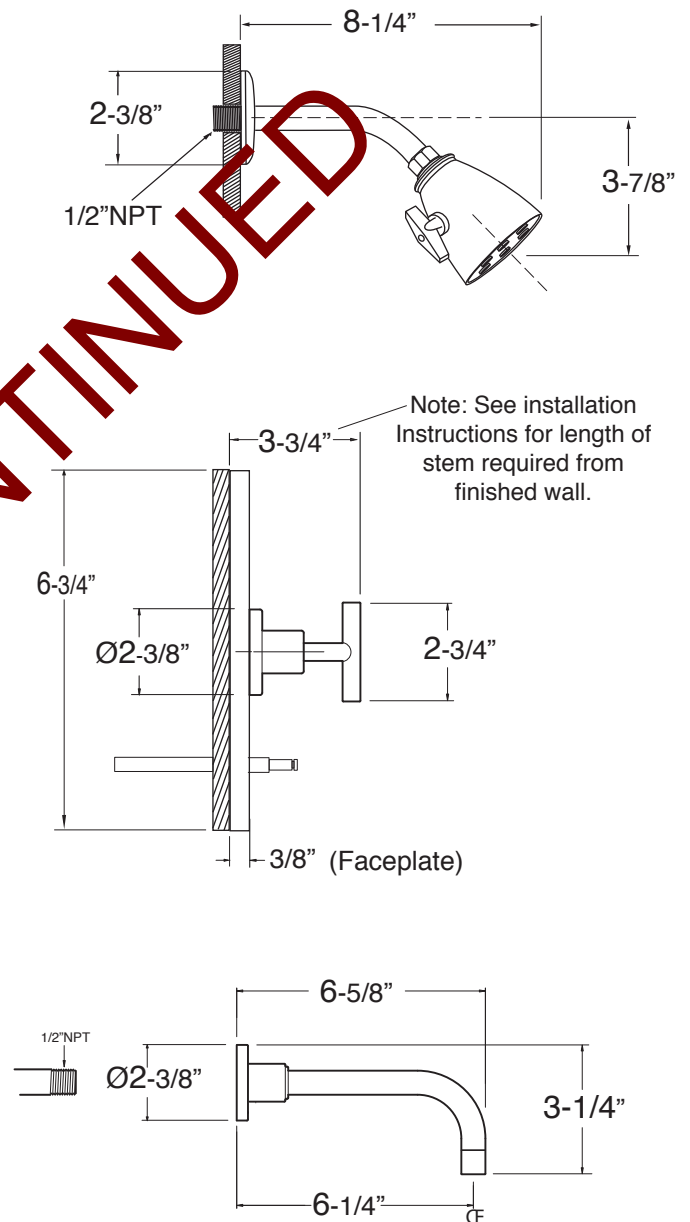
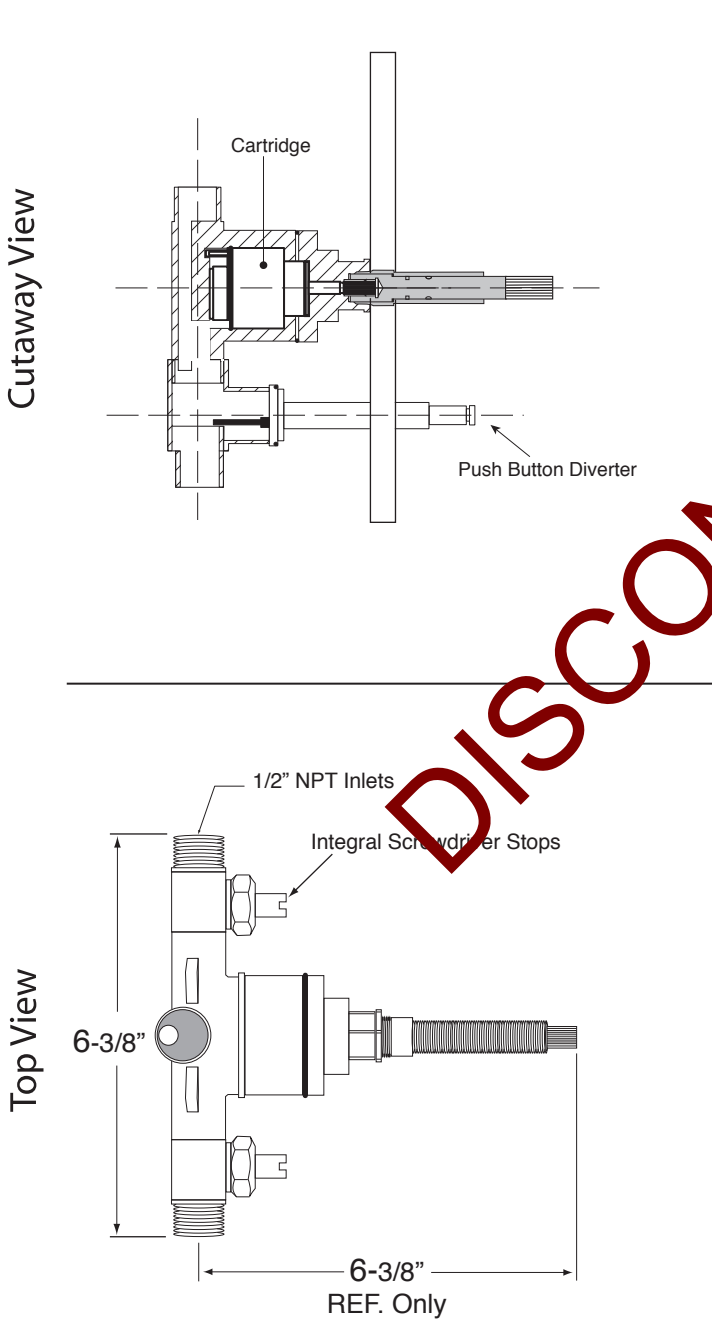

Note: Measurements are subject to change or cancellation. No responsibility is assumed for use of superseded or voided pages.