

## Tribeca (29)

### E-Mini Therm Valve Remote Thermostatic Valve w/Volume Control 18.30.291

**FEATURES:**

- Forged Brass Construction
- Adjustable Hot Limit Safety Stop with Push-In Override
- E-mini thermostatic cartridge 18.30.294
- Cartridge 18.30.0903

• **NOTE:** Leave cap on the out-port to modify to 18.30.291

**MUST purchase Showerhead, Arm, Flange, and other options separately.**

**Rough-In Leftside Cutaway View**

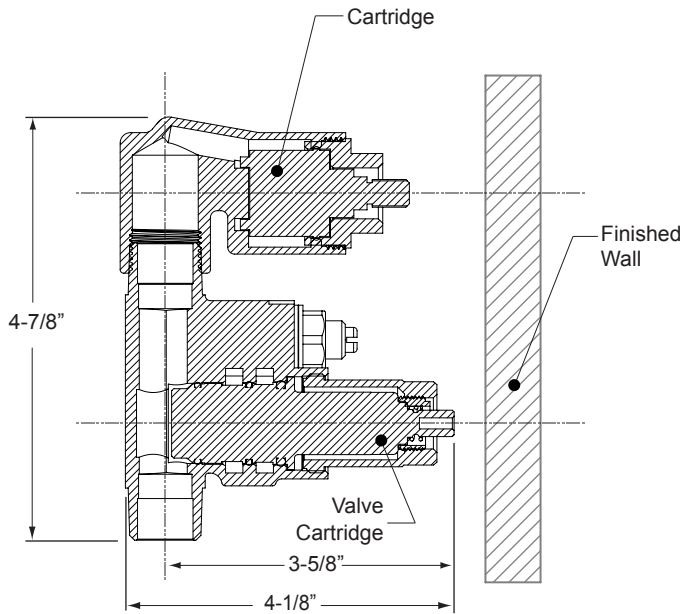

\*NOTE: Stem and All-Thread Tube will be sent with Handle Trim.

**Rectangle Faceplate Leftside View**

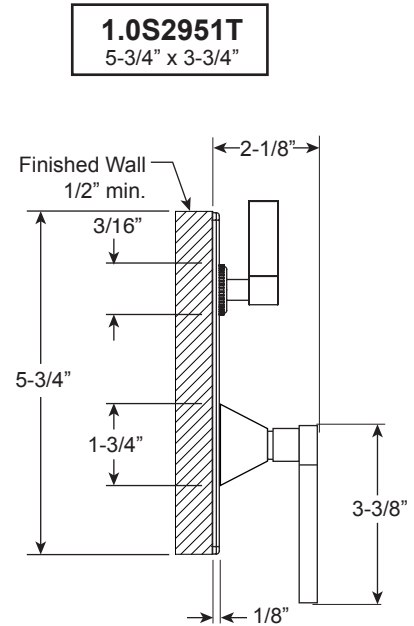

**Rough-In Top View**

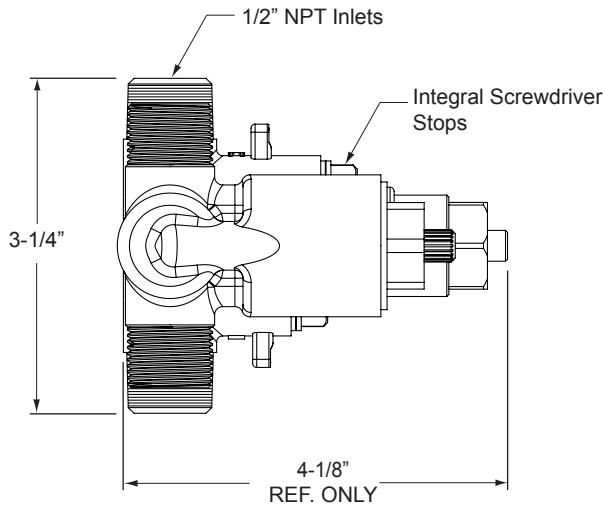

**Round Faceplate Leftside View**

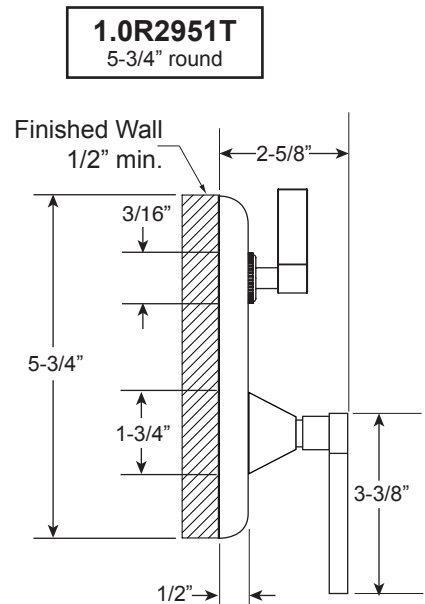

Note: Measurements are subject to change. No responsibility is assumed for use of superseded or voided pages.

## Tribeca (29)

### E-Mini Therm Valve Remote Thermostatic Valve with Two-Way Diverter 18.30.292

**FEATURES:**

- Forged Brass Construction
- Adjustable Hot Limit Safety Stop with Push-In Override
- Flow capacity / Diverter: 4.5 GPM @ 45 psi
- E-mini thermostatic cartridge 18.30.294
- Diverter cartridge 18.30.903

**MUST purchase Showerhead, Arm, Flange, and other options separately.**

**Rough-In Leftside Cutaway View**

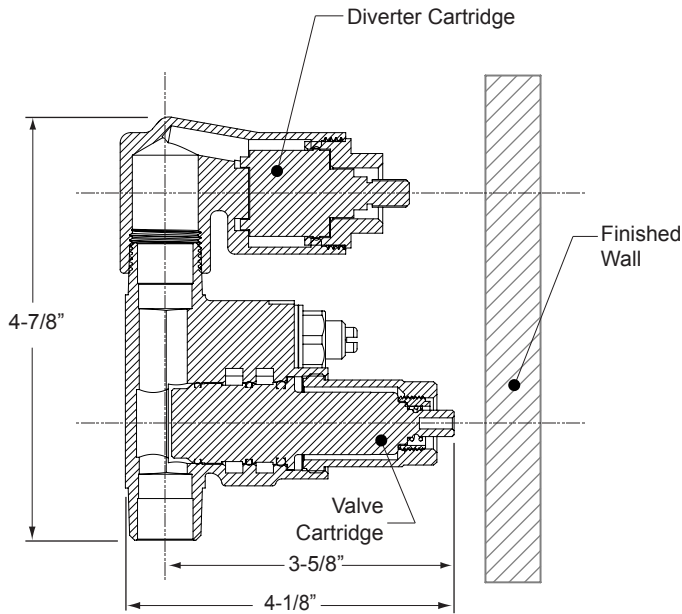

\*NOTE: Stem and All-Thread Tube will be sent with Handle Trim.

**Rectangle Faceplate Leftside View**

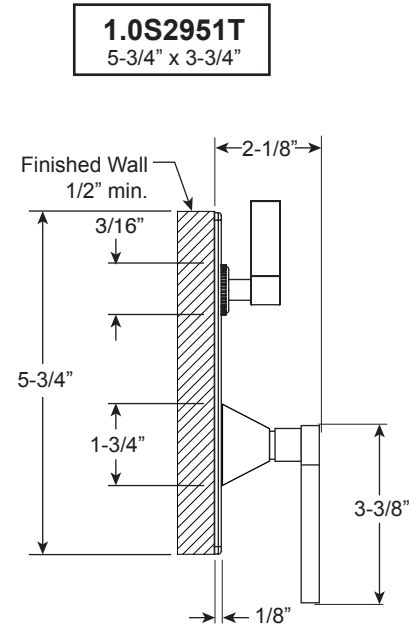

**Rough-In Top View**

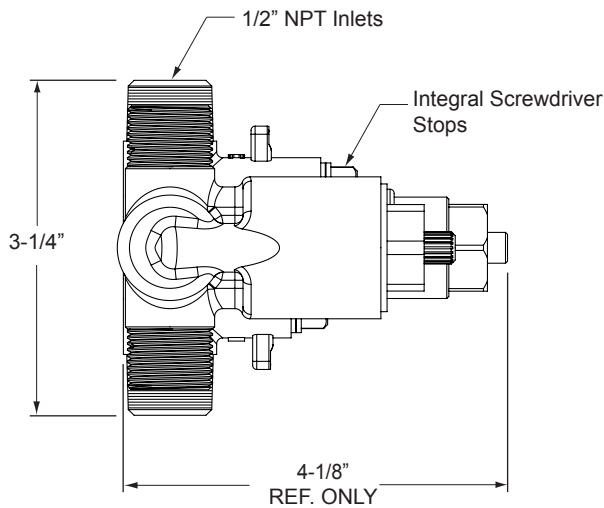

**Round Faceplate Leftside View**

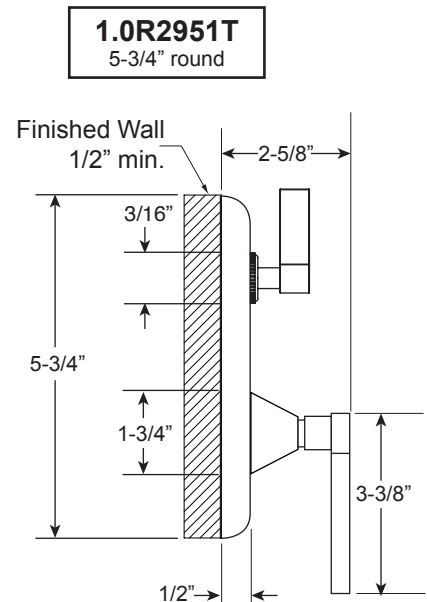

Note: Measurements are subject to change. No responsibility is assumed for use of superseded or voided pages.