

Series 3200

Pressure Balance Shower by Shower Set

FEATURES:

- Forged brass construction
- Valve cartridge 18.30.893
- Diverter cartridge: 18.30.898
- Adjustable hot limit safety stop
- Reversible cartridge
- 4.5 GPM @ 45 PSI
- Certified to meet or exceed the following codes and standards:
ASME A112.18.1/CSAB 125.1-2012

1.006567

(1.006567T - Trim Only)

Luxembourg Handle

16 pt.

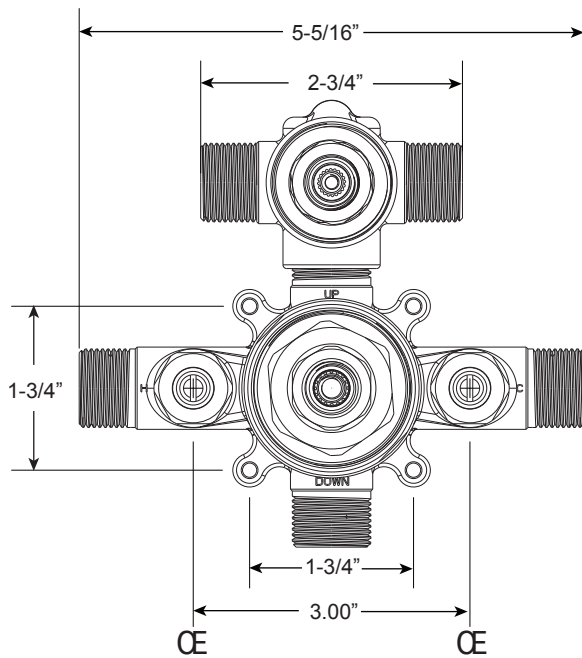

FRONT VIEW

SIDE VIEW

**Note: Stem and all-thread tube will be sent with handle trim.*

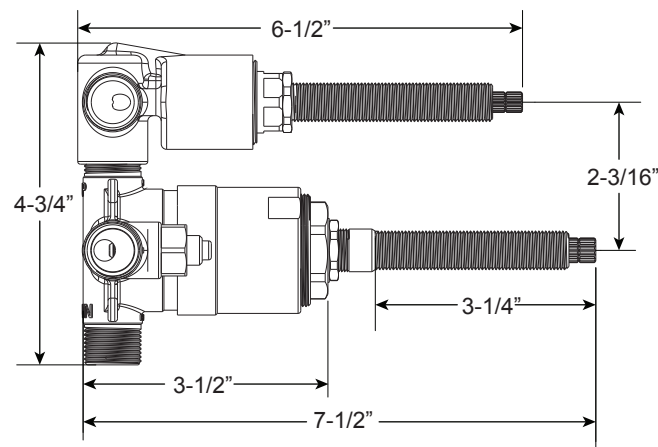

* Current valve in use:
Circa 4/2014 - present
Contact Customer Service
for Older Versions

** For additional information on
cartridges or extension kits,
see 'Rough Valving' section
in current catalog.

Please Note:

Must purchase the two desired shower components separately. See current catalog for shower component options.

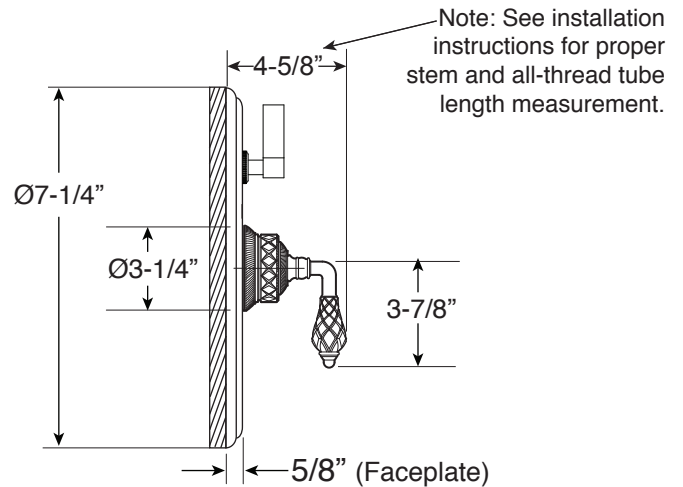

Note: See installation instructions for proper stem and all-thread tube length measurement.