

FEATURES:

- Forged brass construction
- Valve cartridge 18.30.893
- Adjustable hot limit safety stop
- Reversible cartridge
- 5.6 GPM @ 45 PSI
- Includes 1.8 GPM showerhead (18.10.051), arm, and flange

Series 300/350
Pressure Balance Shower Set

1.005564
 (1.005564T - Trim Only)

St. Michel Handle

16 pt.

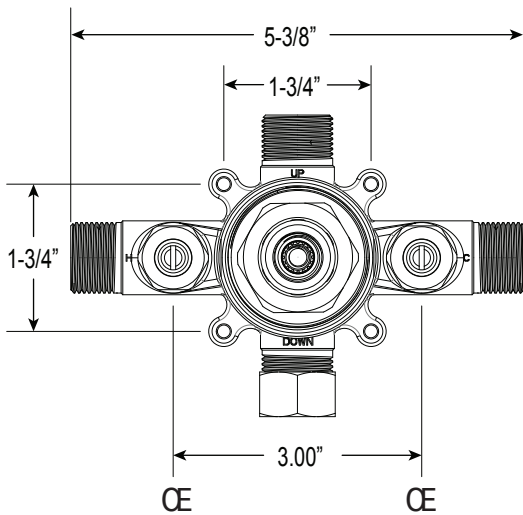

FRONT VIEW

**Note: Stem and all-thread tube will be sent with handle trim.*

SIDE VIEW

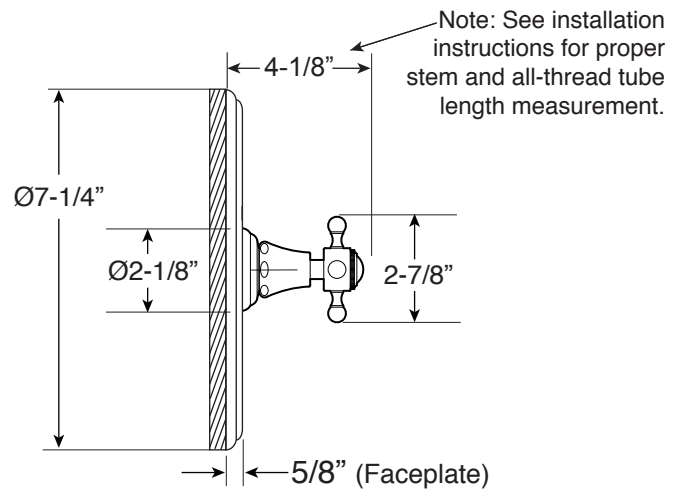
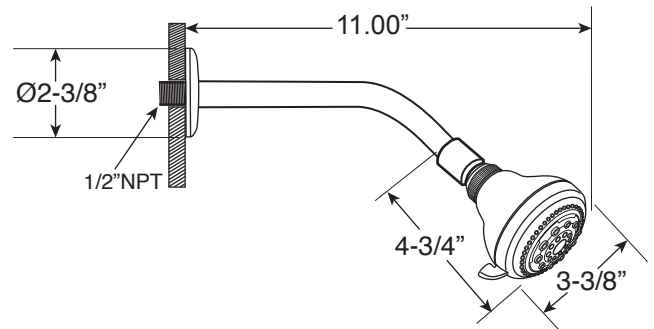
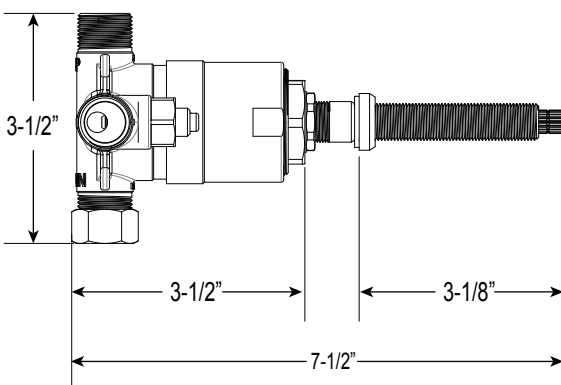

* Current valve in use:
 Circa 4/2014 - present
 Contact Customer Service
 for Older Versions

** For additional information on
 cartridges or extension kits,
 see 'Rough Valving' section
 in current catalog.

Note: Measurements are subject to change. No responsibility is assumed for use of superseded or voided pages.