

## Series 810

1.316868

### Pressure Balance Tub & Shower Set with Piston Lever Handle

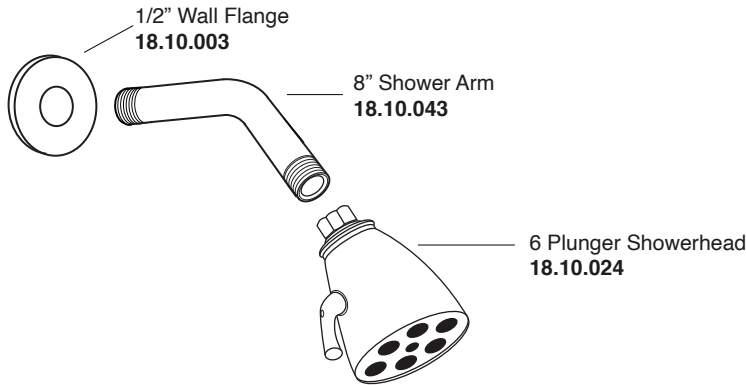

\* Current valve in use:  
Circa 4/2014 - present  
Contact Customer Service  
for Older Versions

\*\* For additional information on  
cartridges or extension kits,  
see 'Rough Valving' section  
in current catalog.

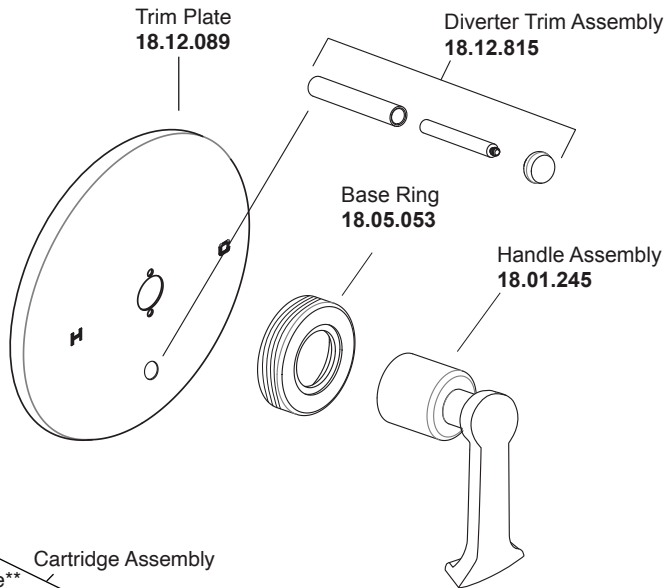

### Pressure Balance Tub & Shower Valve\* 18.30.062

