

Series 400

Pressure Balance Tub and Shower Set

1.400468

(1.400468T - Trim Only)

Charlotte Handle

16 pt.

FEATURES:

- Solid brass construction
- Valve cartridge: 18.30.893
- Diverter assembly: 18.30.894
- Screwdriver stop: 18.30.895
- Adjustable hot limit safety stop
- Reversible cartridge
- 5.0 GPM @ 60 PSI
- Certified to meet or exceed the following codes and standards:
ASME A112.18.1/CSAB 125.1-2012

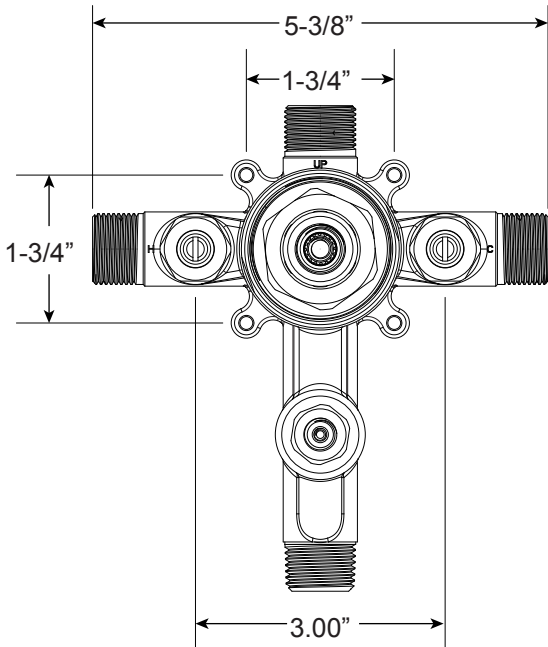

FRONT VIEW

SIDE VIEW

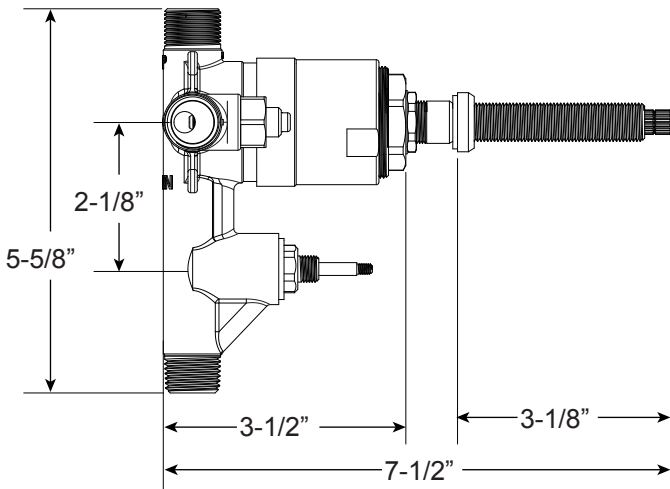

Note: Stem and all-thread tube will be sent with handle trim.

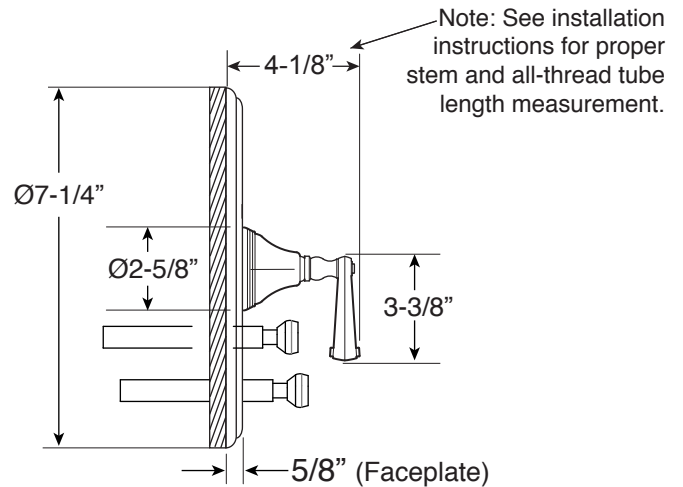
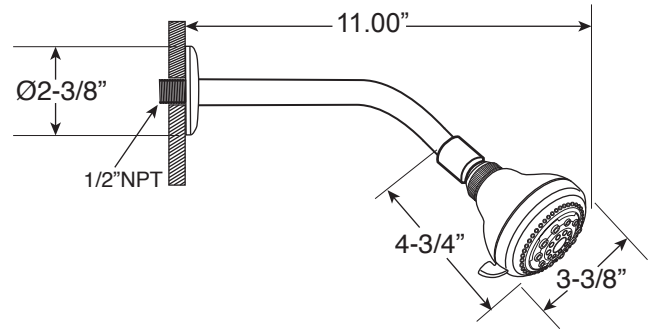

Note: See installation instructions for proper stem and all-thread tube length measurement.

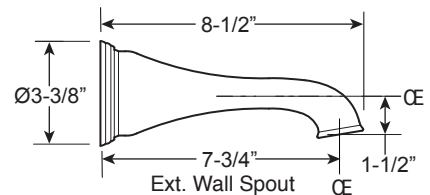
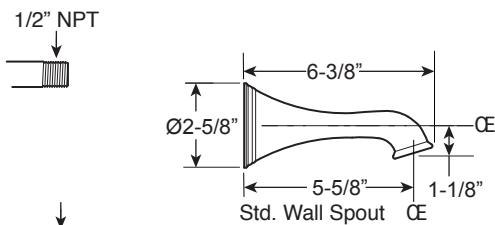

| | |
|---|--|
| Current valve in use: Circa 4/2014 - present Contact Customer Service for Older Versions | For additional information on cartridges or extension kits, see 'Rough Valving' section in current catalog. |
|---|--|

Note: Measurements are subject to change. No responsibility is assumed for use of superseded or voided pages.