

FEATURES:

- Solid brass construction
- Valve cartridge: 18.30.893
- Diverter assembly: 18.30.894
- Screwdriver stop: 18.30.895
- Adjustable hot limit safety stop
- Reversible cartridge
- 5.0 GPM @ 60 PSI

Series 810

1.316868

Pressure Balance Tub
and Shower Set
with Piston Lever Handle

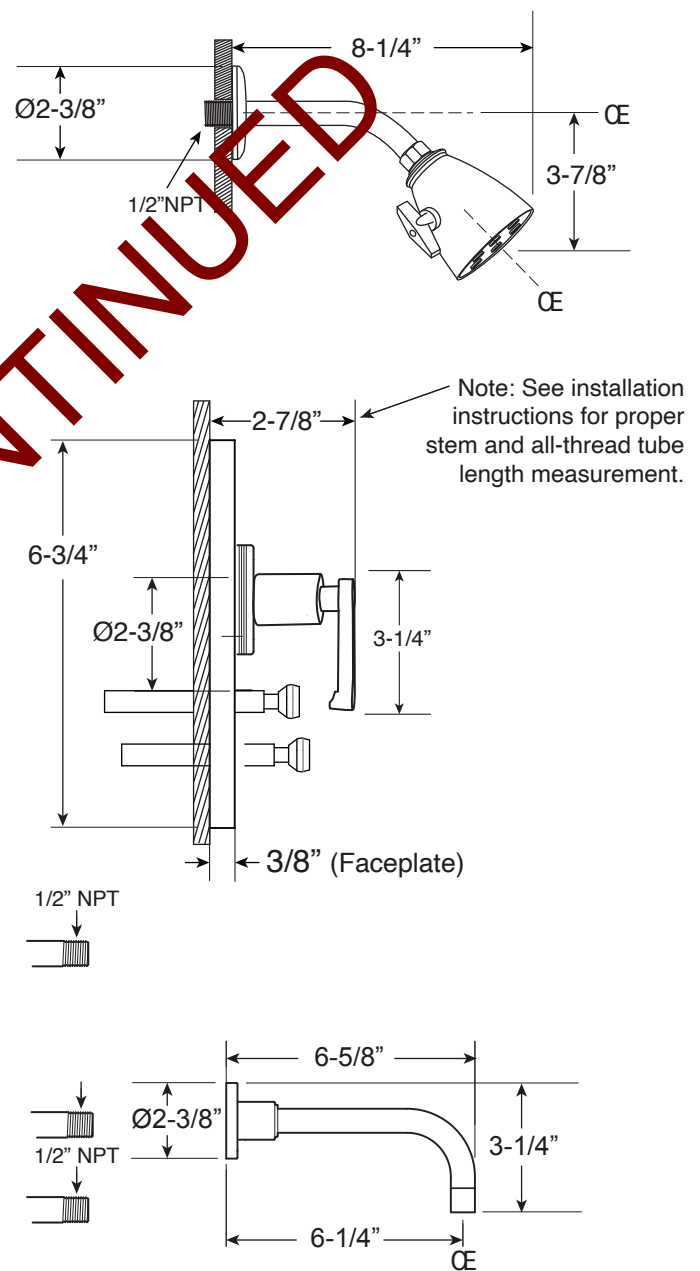
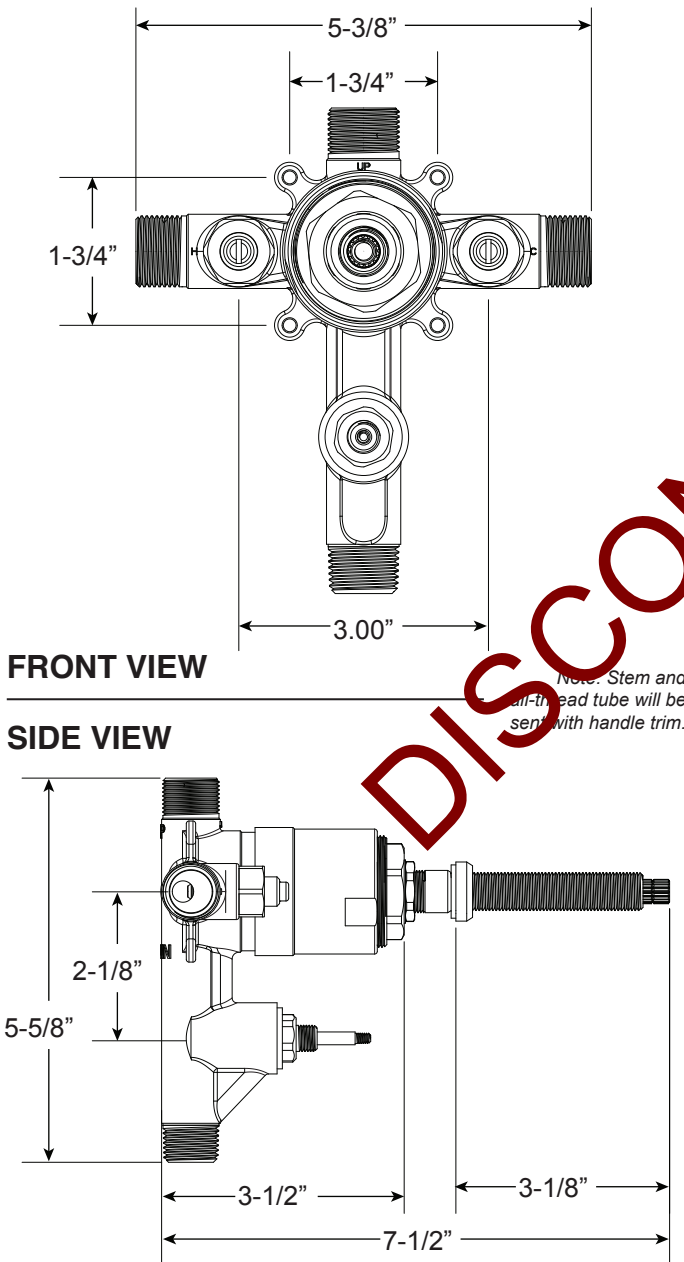

Current valve in use: Circa 4/2014 - present Contact Customer Service for Older Versions	For additional information on cartridges or extension kits, see 'Rough Valving' section in current catalog.
---	--