

FEATURES:

- Forged brass construction.
- Thermostatic valve cartridge: 18.30.082
- Screw driver spring check valve: (2) 18.30.181
- 14.5 GPM @ 45PSI (9.5 top exit)

Note: Separate shut-offs required to operate system.

Series 810

1.076896.V0

1/2" Thermostatic
Valve & Trim

No Volume Control
with Piston Lever Handle
(1.076896.V0T Trim Only)

SIDE VIEW - INSTALLED

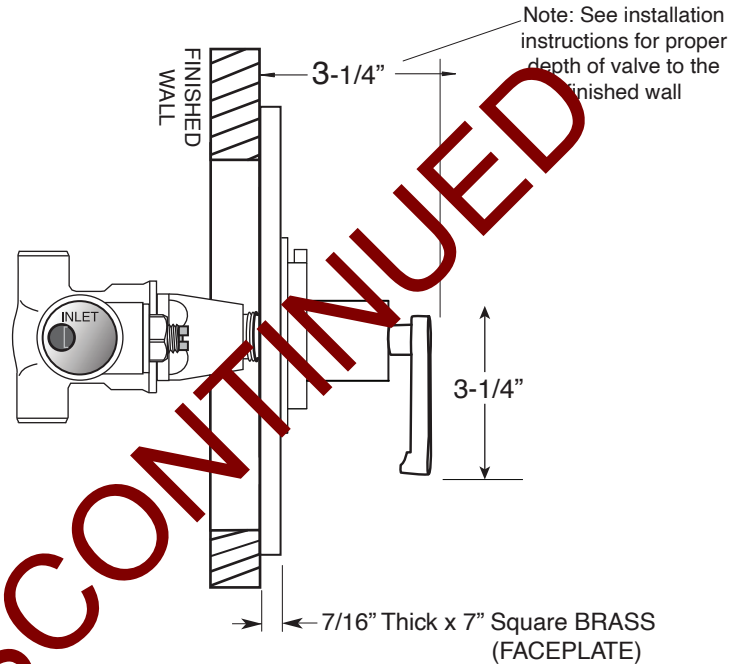

DISCONTINUED

SIDE VIEW - VALVE ONLY

