

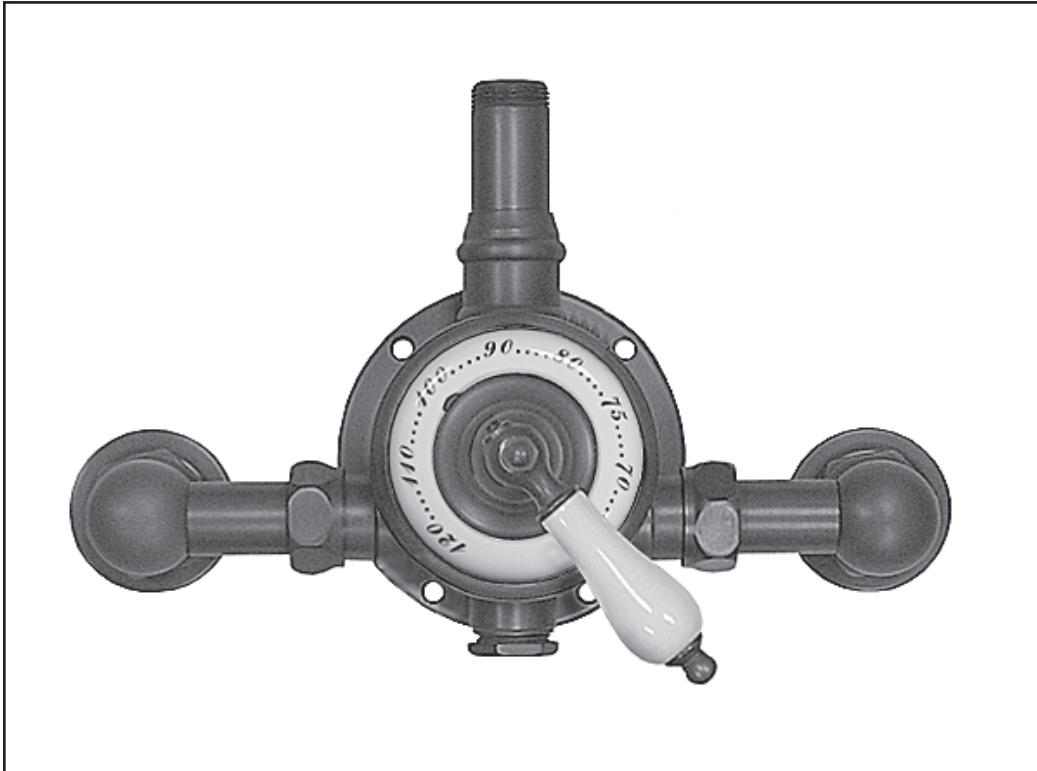

Reserve Exposed Thermostatic Valve Installation Instructions



LEAVE FOR HOME OWNER

Care Instructions:

The product you have just purchased is designed to provide you with long lasting beauty and dependability. To ensure your product's longevity, please follow the following care instructions.

When installing, we recommend you lay all parts on a soft cloth or towel to avoid scratching or damaging the product. To care for your fitting, wipe with a clean, soft, damp cloth and blot dry as often as possible. Never use abrasive cleansers, sponges, or acidic cleaning products as these may damage the finish and VOID THE WARRANTY.



Welcome to the World of Thermostatic Systems Both Exposed and Concealed Valves

Please read ALL instructions, cautions, and care recommendations before beginning installation.

! CAUTIONS !

1. **APPLY NO HEAT/NO TORCH TO THE VALVE ASSEMBLY.**
2. Take special care to protect all components during the construction and installation.
3. Open all boxes carefully. The products are heavy and damage can occur after you open the contents.
4. We suggest all products be set on a soft work surface like an old blanket for review before installation. Cement floors are too hard.
5. Always turn off water at the source before beginning installation.
6. Go slowly - A cautious installation creates a beautiful finished result.
- Caution 7.** Use no pliers, vice grips or channel locks on this finished trim - you will scratch or mar the surface.
- Caution 8.** Use a crescent wrench on all nuts - be deliberate and patient - no damage will happen.
9. If you have the factory installation tool kit, follow the instructions enclosed.
10. Concealed thermostatic systems are the norm in the USA today. Valves are usually installed inside the frame construction and there is no danger from exposed pipes.
11. All of the Exposed Thermostatic Systems are state of the art and meet or exceed all codes for approved products in the USA and Canada.
12. All systems are fail safe and will not allow hot water to exceed 120° degrees Fahrenheit during any showering or bathing experience if properly installed and calibrated.

RESERVE
Collection

13. Each individual bather can adjust the temperature at will while using the shower. Our thermostatic systems have separate temperature controls from the exit controls.
14. Exposed hot water pipes are potentially dangerous to the unsuspecting person. We are used to concealed plumbing pipes inside the walls of a typical home.
15. Be advised that exposed thermostatic systems have a **HOT** water line that can be too hot to touch! **Beware of burns!**
16. **Exposed piping means you can touch the cold and hot water lines.**
17. **Exposed piping means you can see if anything is wrong with your plumbing.**
18. **Exposed piping means you can service your system easily.**
19. **Exposed piping means you don't have to remove your walls if a problem occurs.**
20. We have labeled the hot side as a preliminary caution for the homeowner. Please leave the attached label in place for the homeowner to remove when the installation is complete.
21. **3/4" copper water lines are required for the hot and cold inlets.**
22. Remember the exposed piping is **not a grab bar** and we do not imply in any way that our installation procedures are for any other purpose than to support the exposed pipes on the prepared surfaces of your walls.
23. You must provide wood backing inside the walls to mount the various units correctly (see the attached installation print #2).
24. Be sure the supplied screws will be long enough to reach the interior wood blocking or that the screws supplied with the alligator clips are going to fit in your tile or stone walls (see diagram of suggested framing).
25. The system comes with metal ferrules. The 2 supplied 3/4" metal ferrules are for the 3/4" copper inlets only.
26. All systems have been water tested at the factory to 90 lbs of static and dynamic water pressure. Thus you may find residual water inside the thermostatic valve from this testing.



27. The exposed thermostatic valve has been factory calibrated to deliver a maximum Fahrenheit temperature of 110 to confirm proper operation. In the absence of a thermometer, the maximum water temperature should feel slightly uncomfortable to the hand.
NOTE: It is important that the valve be properly calibrated to preserve its anti-scald feature. For recalibration procedures, (**See Page 8**).
28. Prior to installing the thermostatic body, **flush all water lines** to free up debris. The lines should be flushed long enough to remove any sediment that may come from any new installations including a water heater. It is recommended you flush lines for at least 15 minutes before connecting the new fitting, let water run from the HOT and COLD copper connecting pipe in the shower wall.
29. **Failure to flush thoroughly may damage internal parts!** An in-line water filter is recommended to remove harmful sediments.
31. Water pressure comes from your local water supplier and can be measured at the source. Pressure and water velocity are not functions of the valve.
32. Do not attempt installation of product if you do not understand these instructions. **Qualified plumbers should be used for all installation procedures.**
33. Call the factory if you have any questions.

- Maximum working pressure	145 PSI
- Minimum working pressure	14 PSI
- Recommended working pressure	29 to 58 PSI
- Maximum test pressure	224 PSI
- Maximum hot water temperature	185°F



Shower Heads:

All showerheads and hand showers comply with the approved water flow rate as required by US plumbing codes when we have installed flow restrictors in the heads.

These flow restrictors can clog from lime scale buildup, silt, sand, or debris in the water line caused from or during the construction process. If you wish to clean or service the restrictor, simply use a Phillips screwdriver and back out the plastic part - clean and reinstall.

Always keep Deluxe showerheads level and perpendicular to your floor. If any head is tilted you may not receive a satisfactory shower.

Some showerheads are intentionally designed as Rain Heads. The water exits the 8" and 12" size heads like wonderful soft rain. Increased velocity does not come from the shower valve but from several other outside factors.

The velocity of the water is dependant on your existing street water pressure, the size of the pipes, the water meter and the design of your pipe system.

Consult with the Factory Sales Representative or a Factory Trained Plumbing Contractor when issues occur.



Note: This fitting has been factory assembled, tested and is ready for installation. See the tag attached to the valve to verify factory readiness.

Recommended Instructions:

Read all instructions completely before proceeding!

The Exposed Thermostatic Valve is a controlled shower mixing valve. Temperature is thermostatically controlled by a bi-metal cartridge thermostat that maintains a constant temperature while automatically adjusting and compensating for changes in HOT and COLD inlet pressures and temperatures. Should the COLD supply fail, the valve will immediately shut down to avoid any risk of scalding. Keep in mind that the distance the shower head or other exit is from the valve will determine how fast you feel the instantaneous correction in temperature. The water flow is controlled by a simple quarter turn ceramic cartridge. The Exposed Thermostatic Valve is suitable, without modification, for all types of installations. This includes pumped gravity systems, main pressure water systems and combination boilers.

MEETS AND EXCEEDS I.A.P.M.O. ASSE 1016 STANDARDS AND UNIFORM PLUMBING CODES

PRODUCT CARE:

The Exposed Thermostatic Valve is incredibly easy to maintain. The temperature and flow are controlled by one piece cartridges which are easily removed for cleaning and replacement. See Calibration Instructions to demonstrate how to properly remove the handle. To ensure full water flow, periodically clean the cartridge screens of any debris using a small brush. Rinse thoroughly before returning to the fixture. Drop cartridge into place and reassemble handle pieces as shown on calibration instructions. Soaking the cartridge in a 50/50 solution of clear household vinegar and water will remove lime scale. Regular cleaning each year will extend the life of the cartridge. **Never use a screwdriver on a thermostatic cartridge and NEVER take a thermostatic cartridge apart as you will damage the precise instrument.** Call your dealer or the factory for answers to your questions. **Remember, after removing the cartridge, you must recalibrate.**

INSTALLATION:

The Exposed Thermostatic Valve must be installed with the outlet pointing upwards, so that the HOT water enters on the left, and the COLD water on the right, as shown in Figure A.

THE VALVE WILL NOT FUNCTION IF REVERSED! The inlet elbows are fitted with compression nuts. Be sure to **flush thoroughly all new plumbing for up to 15 minutes** before connecting the valve to clear out all debris in your water lines. The valve should be screwed to the wall with the screws provided.

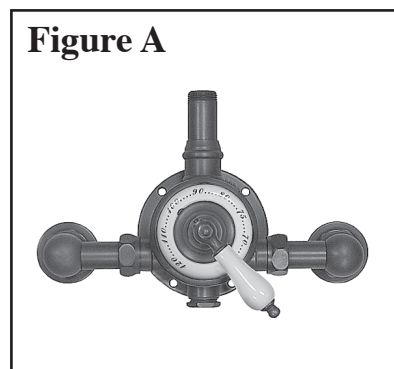

INSTALLATION:

Next, cut the 3/4" copper pipes so that they extend approximately 1" from the finished wall.

(See Figure C below) Slip the wall flange over the pipe. Next, slide on the compression nut so that the bottom fits into the wall flange. Slide the ferrule down the pipe. It will pinch into the copper securing the elbow when you tighten the nut onto the elbow.

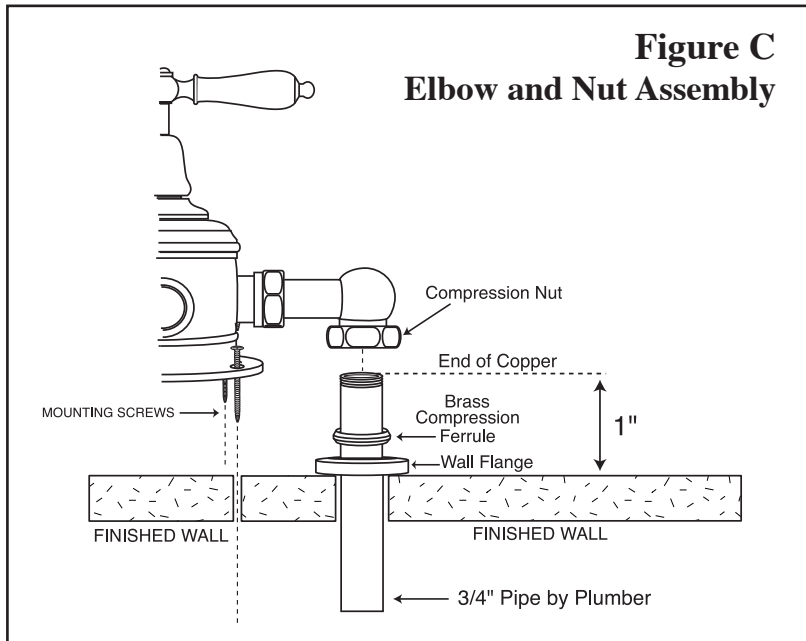

“ Please Note ”: The entire valve body must be installed over the copper pipes - **at one time** - do not separate the components. See Figure D below.

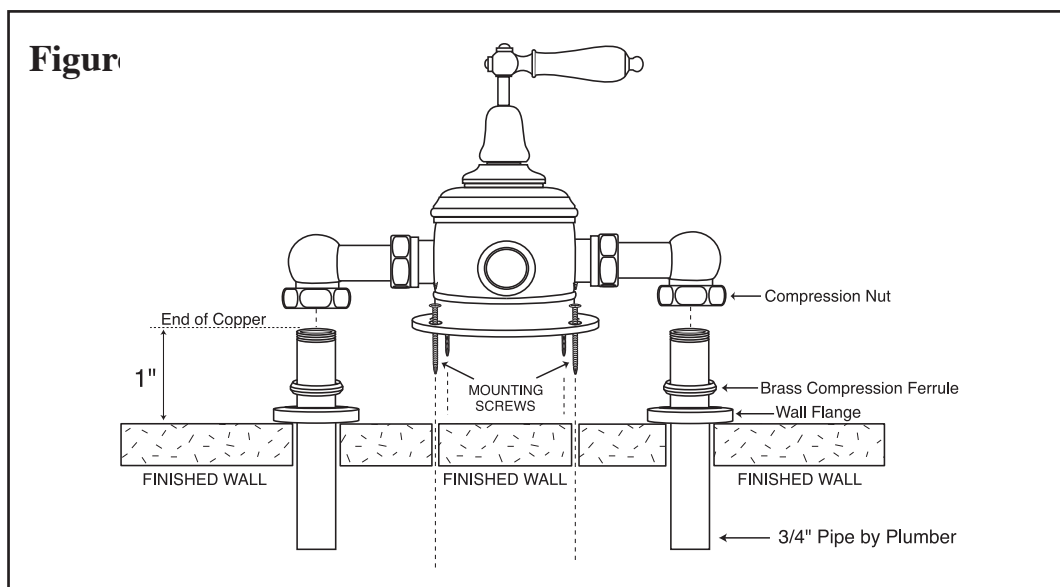

CALIBRATION INSTRUCTIONS:
FOR TEMPERATURE SETTING AND ADJUSTMENTS

Calibration is the simple process by which you control the temperature range of mixed water. The Exposed Thermostatic Valve has been factory tested and calibrated to preserve its anti-scald feature when installed in your home. If you desire a hotter or colder temperature range, you can recalibrate the valve after installation, when both HOT and COLD lines are 100% operational, and all installation debris have been flushed from the water lines and the valve body. The factory has preset the valve at 110°F maximum. You may feel a 2 or 3 degree variance but turning the temperature handle will be the simple way to change the temperature.

TO CALIBRATE TEMPERATURE SETTING: (SEE FULL TEXT ATTACHED)

Under no circumstances is the thermostatic cartridge to be dismantled. Doing so will VOID THE WARRANTY and possibly make the cartridge inoperable. (SEE FULL TEXT)

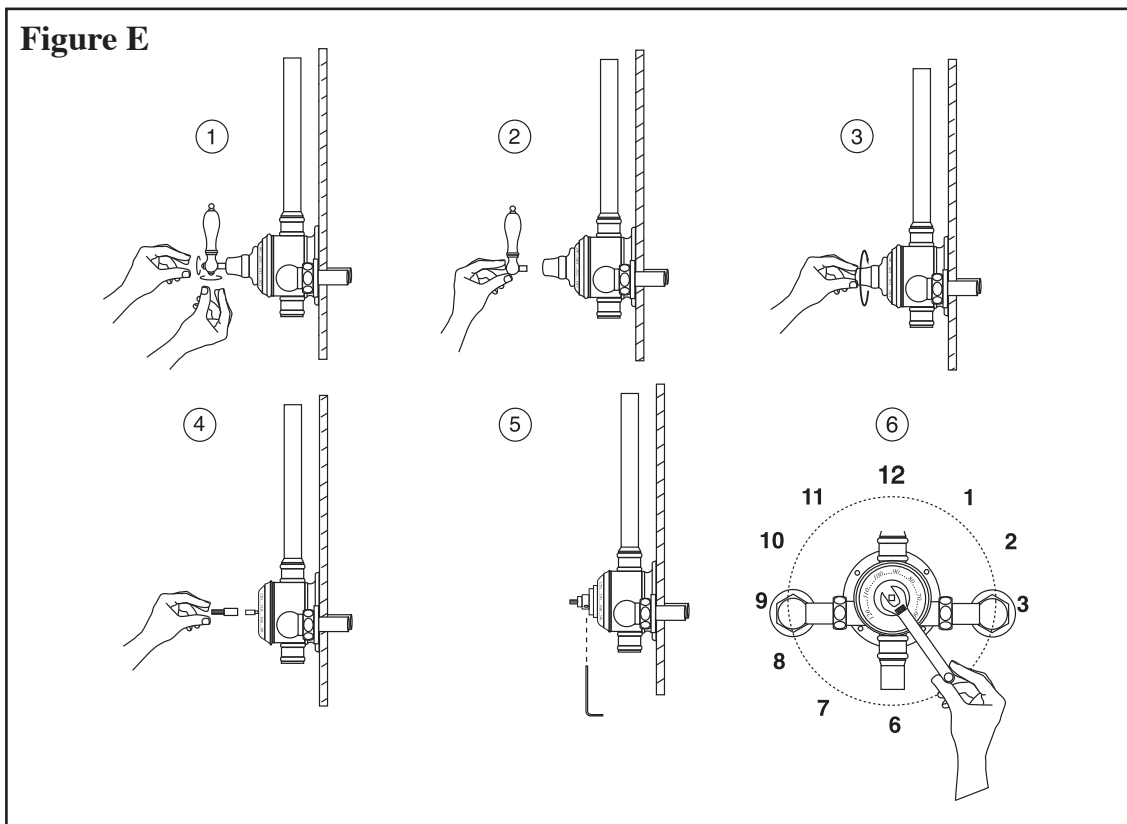

Temperature Calibration

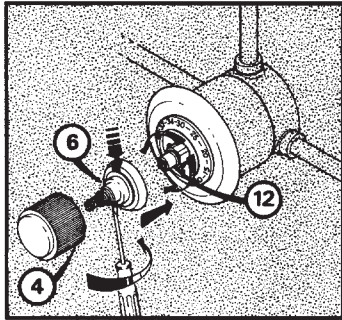

**ALL 3/4"
EUROTHERM
VALVES
CALIBRATE
THE SAME.**

Let the water flow and bring this to a mean temperature by actuating the bushing (**"A" PRINT# 1**). Note this temperature. Place the pointer assembly (**"B" PRINT# 1**) on the bushing and position the "red" index opposite the graduation corresponding to the temperature noted.

Tighten up the pointer assembly (**"B" PRINT# 1**) set screw and fit the handle (**"C" PRINT# 1**) again.

When in use, if a water above 104°F is desired, press the "red" index and turn the knob to the left.

Maintenance

Filter Cleaning

If the cartridge is installed prior to flushing the lines you may inadvertently clog the filters. Dirty filters may lead to a reduction in the flow rate. It is then necessary to clean them with a brush after removing the combination cover cartridge (**"D" PRINT# 1**) from the body of the appliance (see "Cartridge Removal Guide"). Brush the outsides of the filters ONLY.

D. Cleaning the Cartridge

If the cartridge is installed prior to flushing the lines you may inadvertently clog the filters. It will be necessary to remove the cartridge from the mixing valve - never take the cartridge apart or you will void all warranties. Simply soak the entire cartridge in (vinegar and water solution 50/50) for 1 to 3 hours and reinstall the valve. 90% of the time the valve will then work normally. See Operating Incidents for further details.

Cartridge Removal Guide (Future reference ONLY)

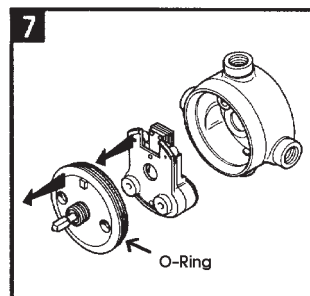
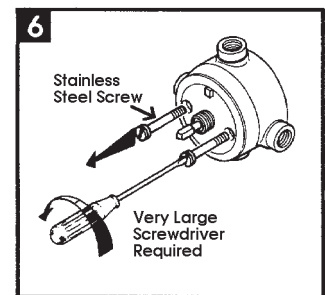
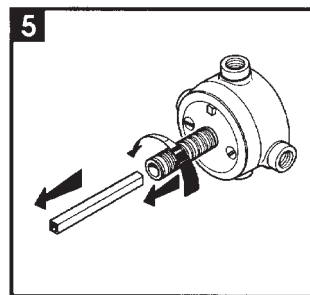
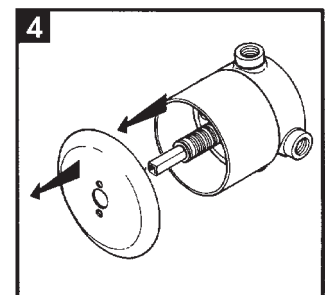
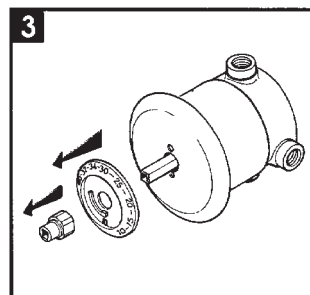
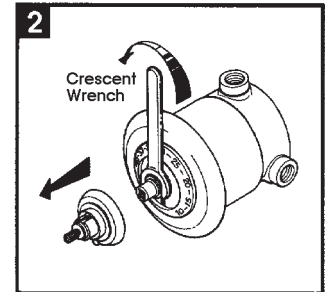
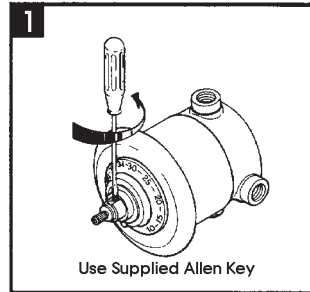

Emptying in case of Frost

When the appliance is exposed to freezing conditions it is ESSENTIAL to empty it:

- either by turning on a tap at the bottom outlet
- or by opening the cover (3) of the appliance.



OPERATING SOLUTION FOR EUROTHERM THERMOSTATIC MIXERS

In the event of an operating problem with a Eurotherm thermostatic mixer, review the following information. Make sure hot and cold inlets are correctly connected to the marked hot and cold side of the mixer. Be sure there is sufficient water pressure and that you have calibrated the mixer valve correctly. Check whether the screens are clean of debris. The main operating problems, their causes and remedies are described below. If the problem is caused by the mixer, return the replaceable mechanism or the complete mixer (industrial models) to the factory.

OPERATING DEFECTS	REASON	REMEDIES
1 - When first using a new appliance, only hot or cold water is delivered.	<ul style="list-style-type: none"> - The water inlets are reversed. - The bimetal strip is not properly centered. - The distributing valve is not free. 	1 5 7
2 - The mixed water temperature follows the position of the graduated regulator but with a certain delay.	<ul style="list-style-type: none"> - The control system is incorrectly calibrated. 	2 6
3 - The appliance does not deliver mixed water or only when the regulator is turned up all the way.	<ul style="list-style-type: none"> - One of the water inlets doesn't work. 	3
4 - The mixed water is delivered in spurts and the flow rate is low except at one temperature or the limited temperatures.	<ul style="list-style-type: none"> - One of the water supplies doesn't provide sufficient water. 	4
5 - From time to time the appliance only delivers hot or cold water.	<ul style="list-style-type: none"> The bimetal strip is not properly centered. - The distributing valve is not free. 	5 7 8
6 - The water is always supplied at the same temperature hot or cold.	<ul style="list-style-type: none"> - The bimetal strip does not move the distributing valve: <ul style="list-style-type: none"> a) Because the distributing valve is not free. b) Because the regulating screw does not act on the mechanism. 	7 10 8
7 - The temperature is irregular, especially when flow rates are low.	<ul style="list-style-type: none"> - There are foreign particles beneath the membrane. - The membrane is damaged. 	8
8 - Insufficient mixed water is supplied.	<ul style="list-style-type: none"> - Pressure is too low. - One of the water supplies is insufficient. 	3 9
9 - The different water supplies intercommunicate in the mixer.		6

PRINT 1

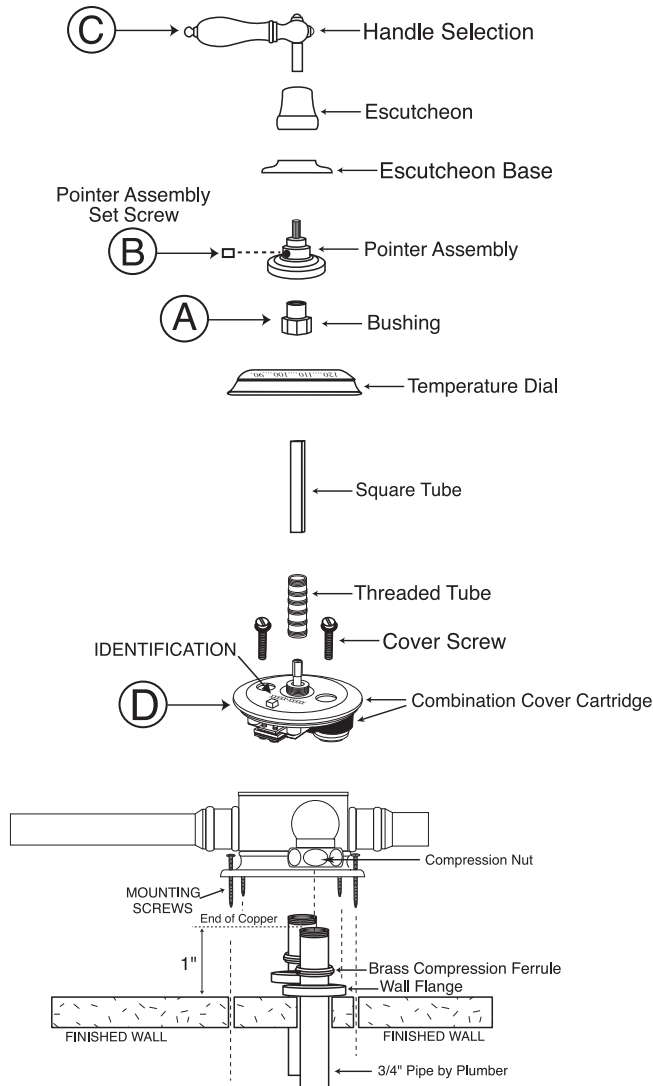

TROUBLE SHOOTING:

The Exposed Thermostatic valve is remarkably dependable and reliable, providing you with a lifetime of service and beauty. The following three problems, and the simple solutions to each, have accounted for nearly all difficulties with this valve.

1.) After Installation the shower only runs HOT or COLD water, and will not mix.
SOLUTION: You have the HOT and COLD plumbed the wrong way around. The correct plumbing is HOT on the LEFT and COLD on the right.

2.) The shower will not run hot enough when first installed. **SOLUTION:** First verify that the water heater is set at 135°F or more. If such is the case, then maximum temperature of the cartridge needs to be set at a higher set point. To readjust the temperature range, follow **CALIBRATION INSTRUCTIONS** .

3.) Cold water tracking through the valve into the hot system on combination boiler systems. **SOLUTION:** This is prevented in the Exposed Thermostatic Valve by built-in check valves in the inlets. Check and clean the built-in valves. There may be debris in the plastic check valve.

Installation begins by selecting the centerline of 2" x 4" backing studs at the factory suggested location of 41" as shown in **(Print 2)**. The mounting plate is secured through the use of four metal screws.

Note: The wall surface must be level on all sides of the centerline, otherwise the thermostatic system will not look level and straight when installed.

RECOMMENDED TYPICAL WALL FRAMING CONCEPT

PRINT 2

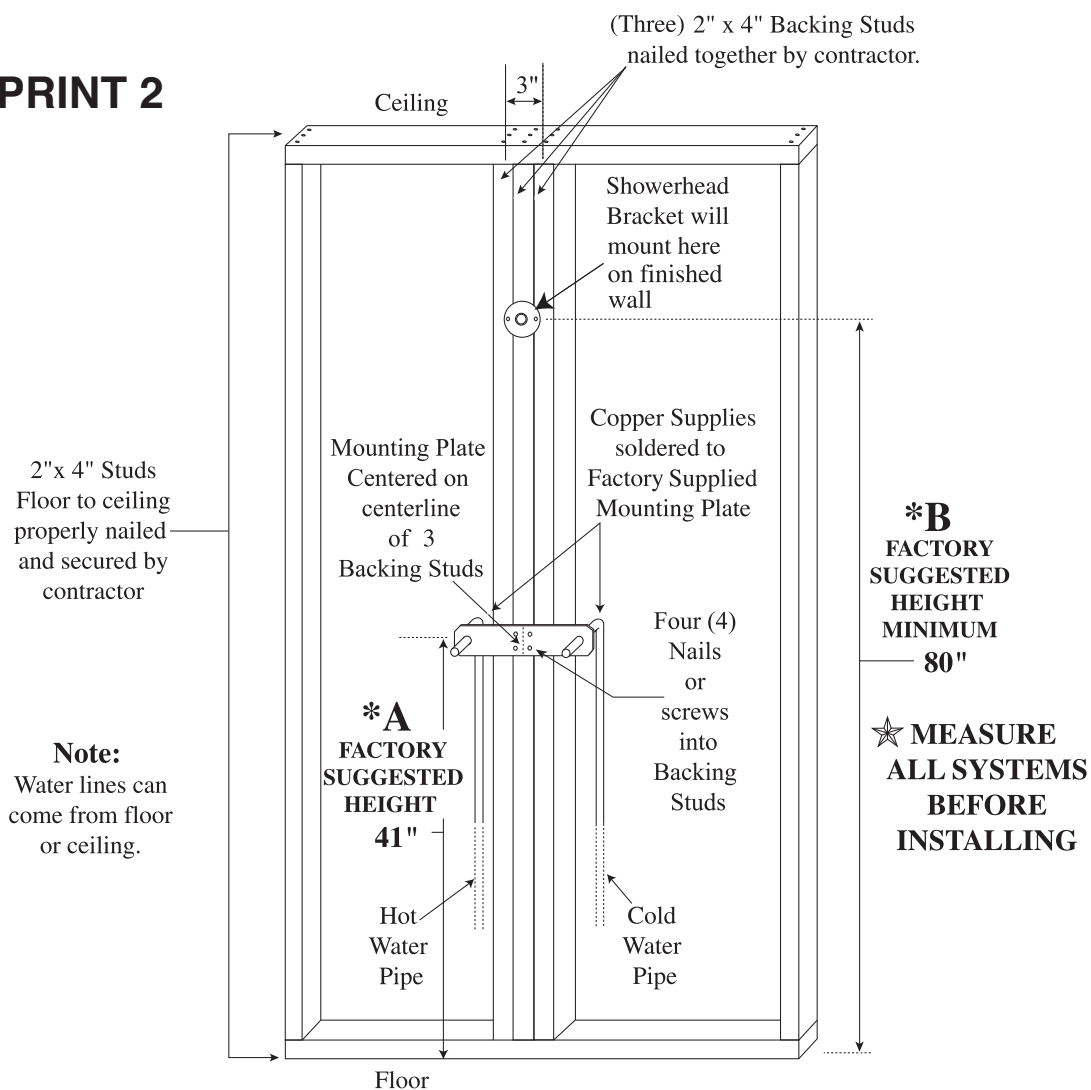

*** Note: These are factory suggestions only - The 80" Height at *B will allow a 6'5" tall person to walk underneath without bending.**

Typical Finished Installation of Exposed Thermostatic Wall Units Tub and Shower with Handshower

PRINT 3A

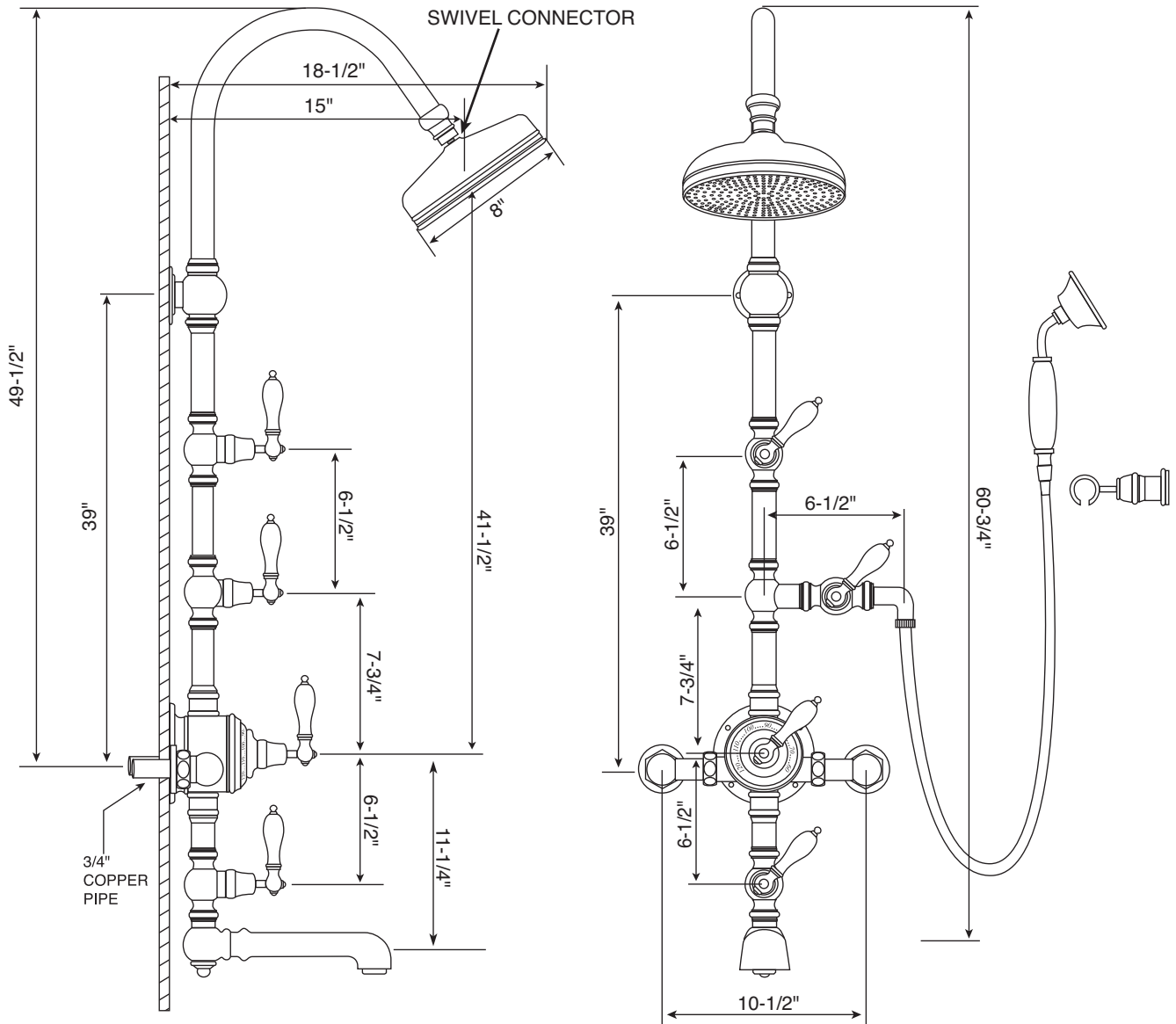

Note: Do not rough out without copper rough-in guide.
Guide may be sent ahead upon request.

Replacement Thermo Cartridge 18.30.176

Typical Finished Installation of Exposed Thermostatic Wall Units Tub and Shower

PRINT 3B

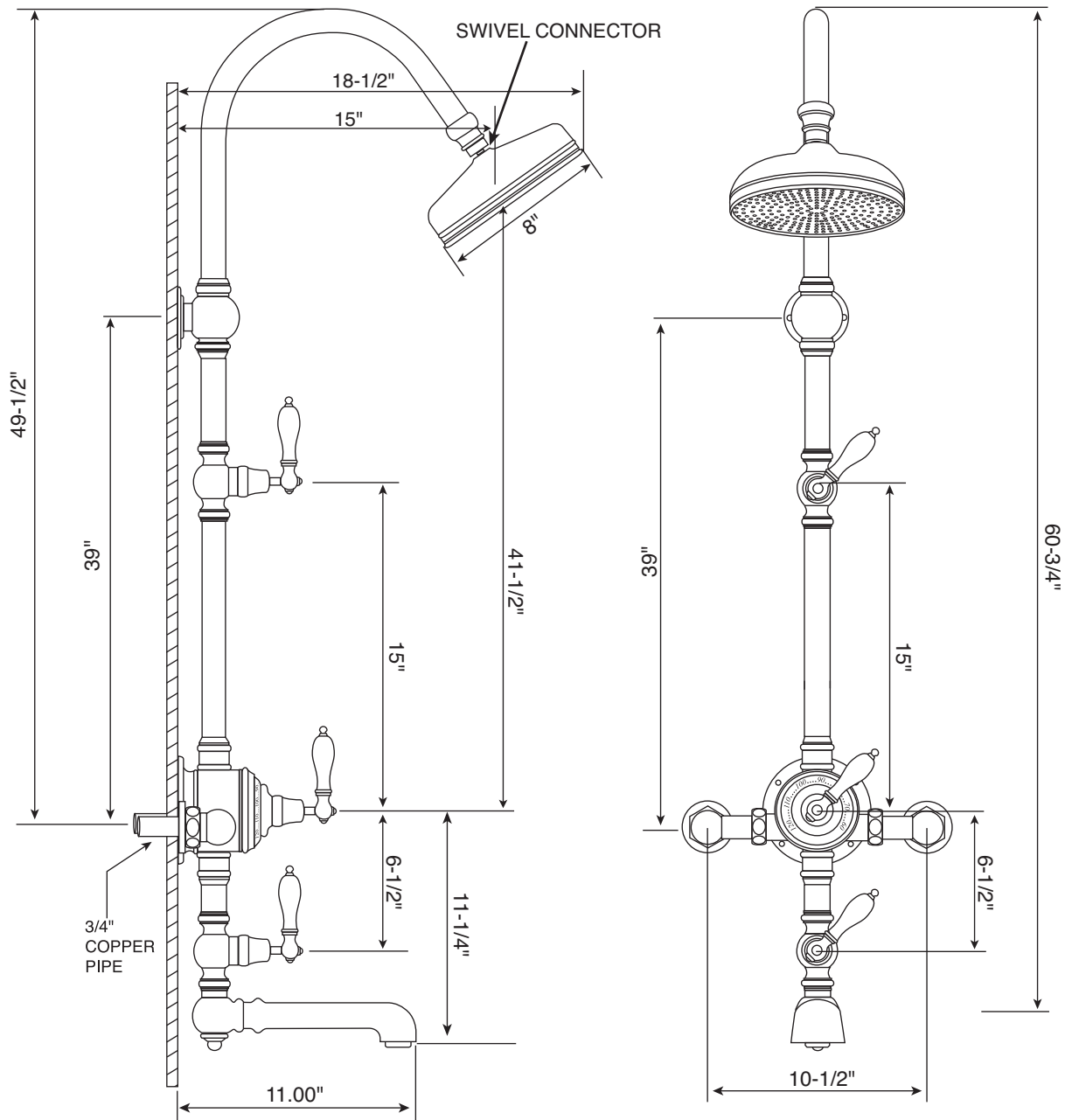

Note: Do not rough out without copper rough-in guide.
Guide may be sent ahead upon request.

Replacement Thermo Cartridge 18.30.176

Typical Finished Installation of Exposed Thermostatic Wall Units Shower with Handshower

PRINT 3C

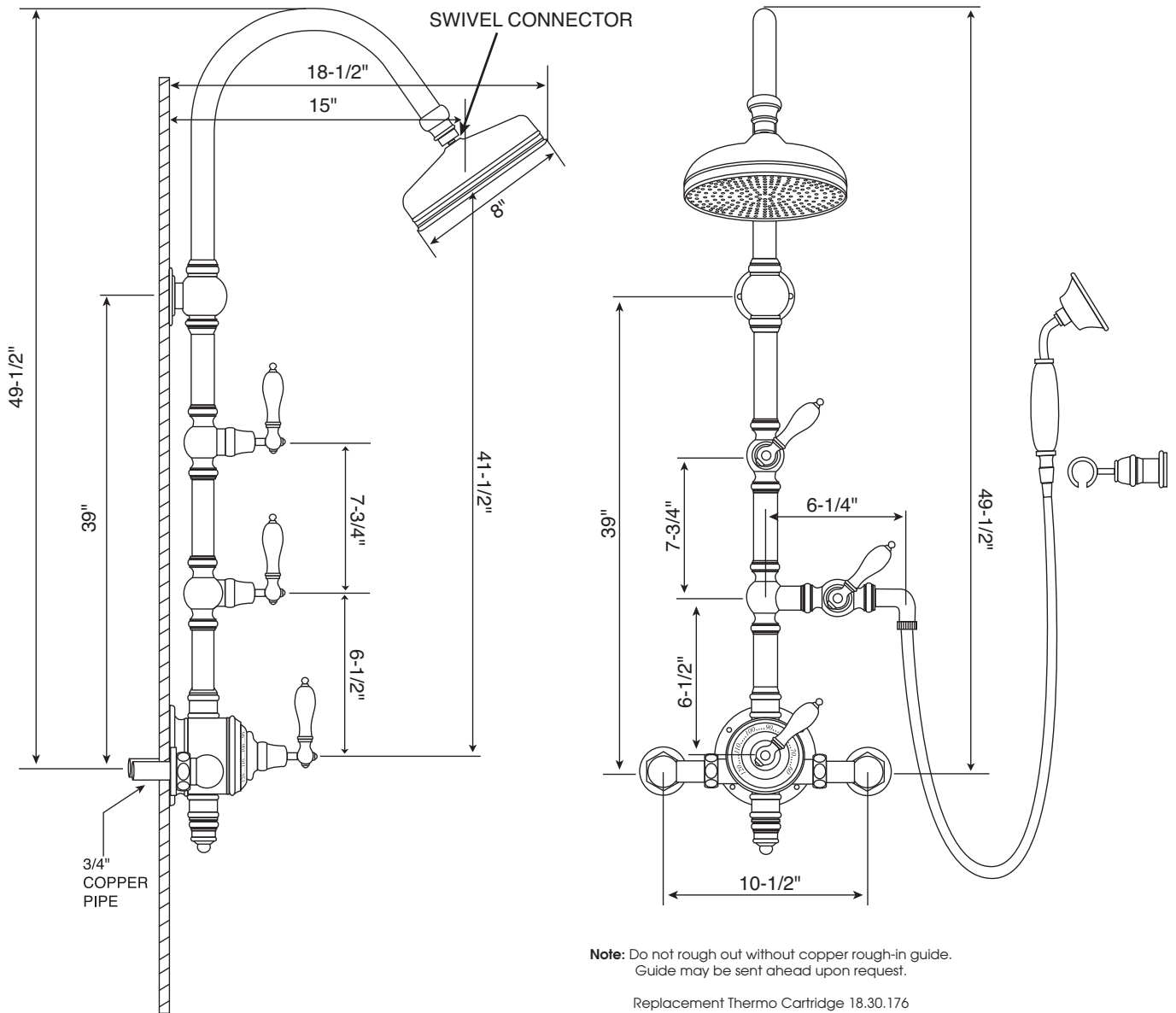

SUGGESTED INSTALLATION OF MOUNTING FOR RESERVE EXPOSED THERMOSTATIC SYSTEM.

THIS PLATE IS INSTALLED ON THE WOOD BACKING DESIGNATED ON PRINT 2.
"SEE ACTUAL PART"

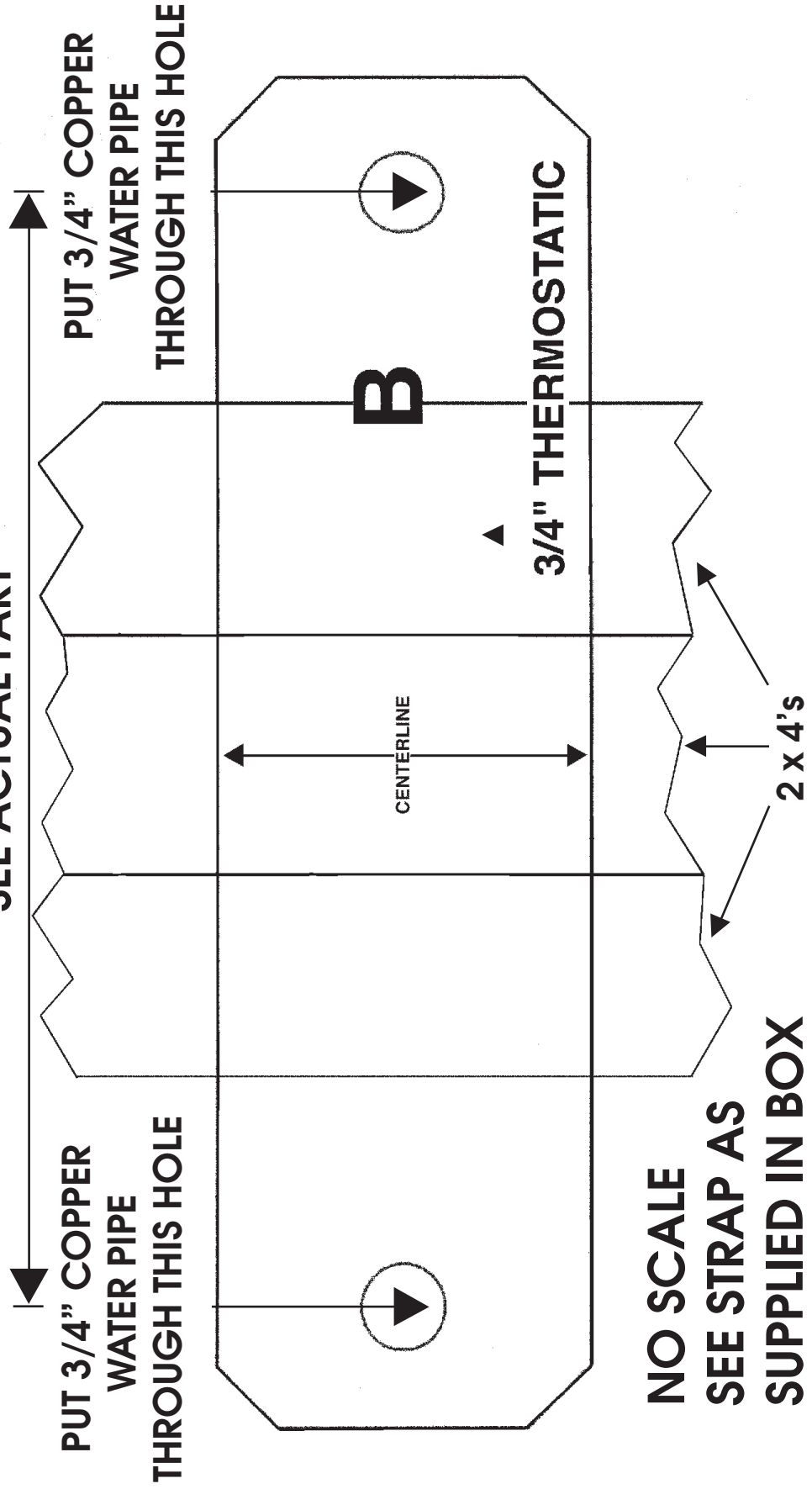

Product/Finish Warranty: American Faucet & Coatings Corporation warrants that products are free from defects in materials and workmanship for five (5) years from date of invoice. In addition, our Finish Warranty provides limited LIFETIME coverage for Chrome & PVD finishes, five (5) years for Omega powder coated finishes & Polished Gold. Living finishes are warranted for workmanship only. If any material proves to be defective after inspection by our company, it will be repaired or replaced at our discretion at no charge. However, no claims for labor, shipping costs, or consequential damages will be accepted.

What we will do: We will restore any product whose finish proves to be defective back to its original finish at no charge during the appropriate warranty period stated above. Proof of purchase must be provided. After the warranty period, American Faucet and Coatings Corporation will refinish any of its faucets at the prevailing appropriate charge.

What you must do: Products must be properly installed according to our instructions and specifications & are for residential use only. The faucets cannot be altered in any way. Maintenance and cleaning must be done accordance with the instructions provided with the product.

How to obtain service: Send your name, address, and telephone number along with a statement describing the nature of the problem and your paid sales slip or other proof of purchase to:

**American Faucet & Coatings Corporation
3280 Corporate View
Vista, CA 92081**

We will then contact you and take appropriate action. Do not send us any part(s) unless we have contacted you and have sent you an approved RGA form. All transportation charges for returned goods must be paid by the customer.

What is not covered: This warranty does not cover the crystal/glass, or porcelain products of any faucet or the drain assembly or aerator on other than the Chrome or PVD finishes. This warranty also does not cover damage caused by accident, alterations, misuse, abuse, normal wear and tear, lime deposits, direct exposure to salty air or corrosive materials, or the color change that takes place with the passage of time, or use in any manner contrary to American Faucet and Coatings Corporation's printed instructions. In the case of in-the-wall installations American Faucet and Coatings Corp. will assume no liability if there is no access. **In no event will we be liable for labor of any kind, incidental or consequential damages.** This warranty is extended in lieu of all other expressed or implied warranties, whether oral or written. **Many installation compounds are harmful to brass and metal finishes. The use of any lead-based or acidic curing adhesive, silicone, mastic, or plumber's putty on or near our finished products will void the finish warranty. Use only sealants which are neutral curing and are not reactive with metal and brass finishes.** American Faucet & Coatings Corporation reserves the right to change, modify or alter its products as deemed necessary. This warranty supersedes any other American Faucet & Coatings Corporation warranties, whether oral or written.

Unless otherwise contrary to state law governing the purchase, American Faucet and Coatings Corporation's liability will not exceed the wholesale price for the American Faucet and Coatings Corporation product considered defective. This warranty gives you specific legal rights, and you may also have other rights which vary from state to state. Some states do not allow exclusion of incidental or consequential damages, so the above limitation may not apply to you.

LIFETIME WARRANTY ON 1/4 TURN CERAMIC DISC CARTRIDGE

Should the ceramic disc cartridge in your faucet ever fail, American Faucet & Coatings Corporation will replace the failed part free of charge to the original purchaser of the product. Your cost will be a \$7.95 handling and mailing charge. Labor not included. When ordering replacements, denote for widespread or centerset lavatory, Roman Tub, or other. Include age of faucet. (This does not include thermostatic, pressure balance, or diverter cartridges.)

**CONSUMER WARNING
CALIFORNIA PROPOSTION 65 WARNING**

Among other chemicals known to cause harm, this faucet contains lead, a chemical known to the State of California to cause birth defects or other reproductive harm.

All faucets and products made of leaded brass alloys, even those that comply with U.S. Environmental Protection Agency regulations, contribute small amounts of lead to water that is allowed to stand in contact with the brass. This faucet complies with all E.P.A. regulations regarding the amount of lead used in plumbing brass and solder. The amount of lead contributed by any faucet is highest when the faucet is new. The following steps will reduce potential for exposure to lead from faucets and other parts of the plumbing system:

- Always run the water for a few seconds prior to use for drinking or cooking.
- Use only cold water for drinking or cooking.
- If you wish to flush the entire plumbing system of water that has been standing in the pipes or other fittings, run the cold water until the temperature of the water drops, indicating water coming from the outside main.
- If you are concerned about lead in your water, have your water tested.