

FEATURES:

- Forged brass construction
- Built-in diverter valve assembly
- 8" Center to Center available on request:
18.30.003 (16pt.) 78.30.003 (20pt.)
- Replacement 1/4 turn cartridges:
COLD 18.30.035
HOT 18.30.036
- Diverter Cartridge 18.30.012
- Additional stem extension kits available (for use on top of original stem extensions upon installation too deep into the wall)
18.30.049 (16pt.) 78.30.049 (20pt.)

3-Valve Roughs

10" Spread

18.30.009 (16pt.)

78.30.009 (20pt.)

Top View

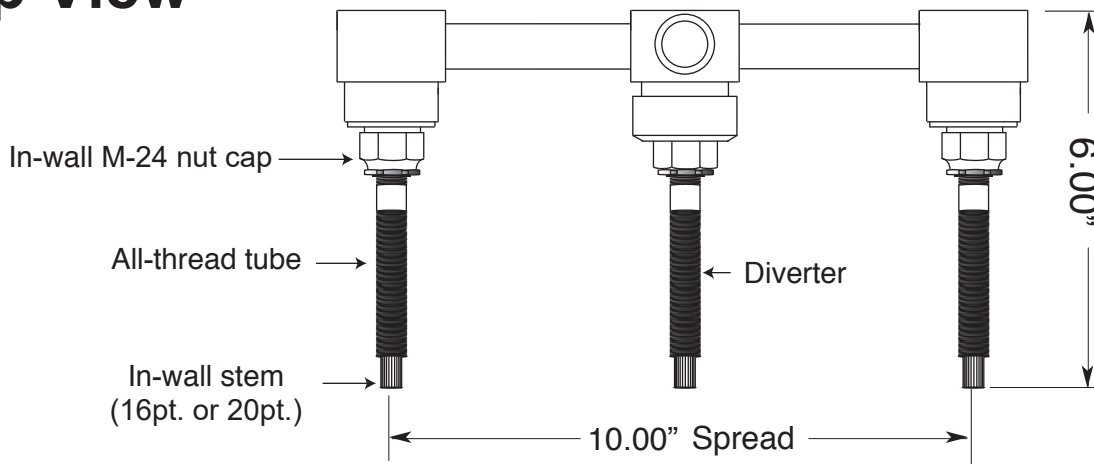

Side View

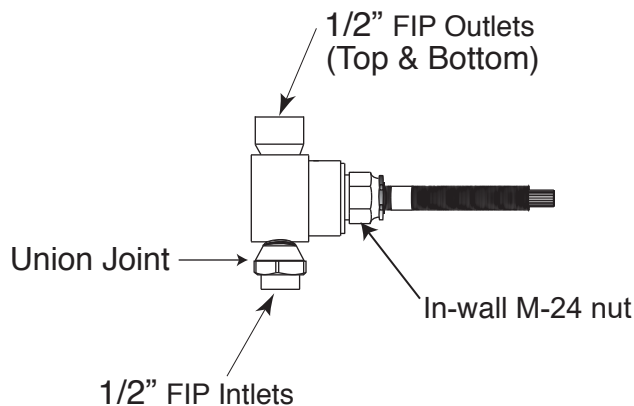

NOTE: See installation instructions for length of stem required from finished wall

NO HEAT-NO TORCH

Note: Measurements are subject to change or cancellation. No responsibility is assumed for use of superseded or voided pages.