

**1" Thermostatic Sets with Dual Exits  
and without Integral Stops  
Installation Instructions  
Valve# 18.30.072**

**Maximum working pressure 145 PSI  
Minimum working pressure 14 PSI  
Recommended working pressure 29-58 PSI  
Maximum test pressure 224 PSI Maximum  
hot water temperature 185°F**

**Note: Separate Shut-offs  
required to operate system.**

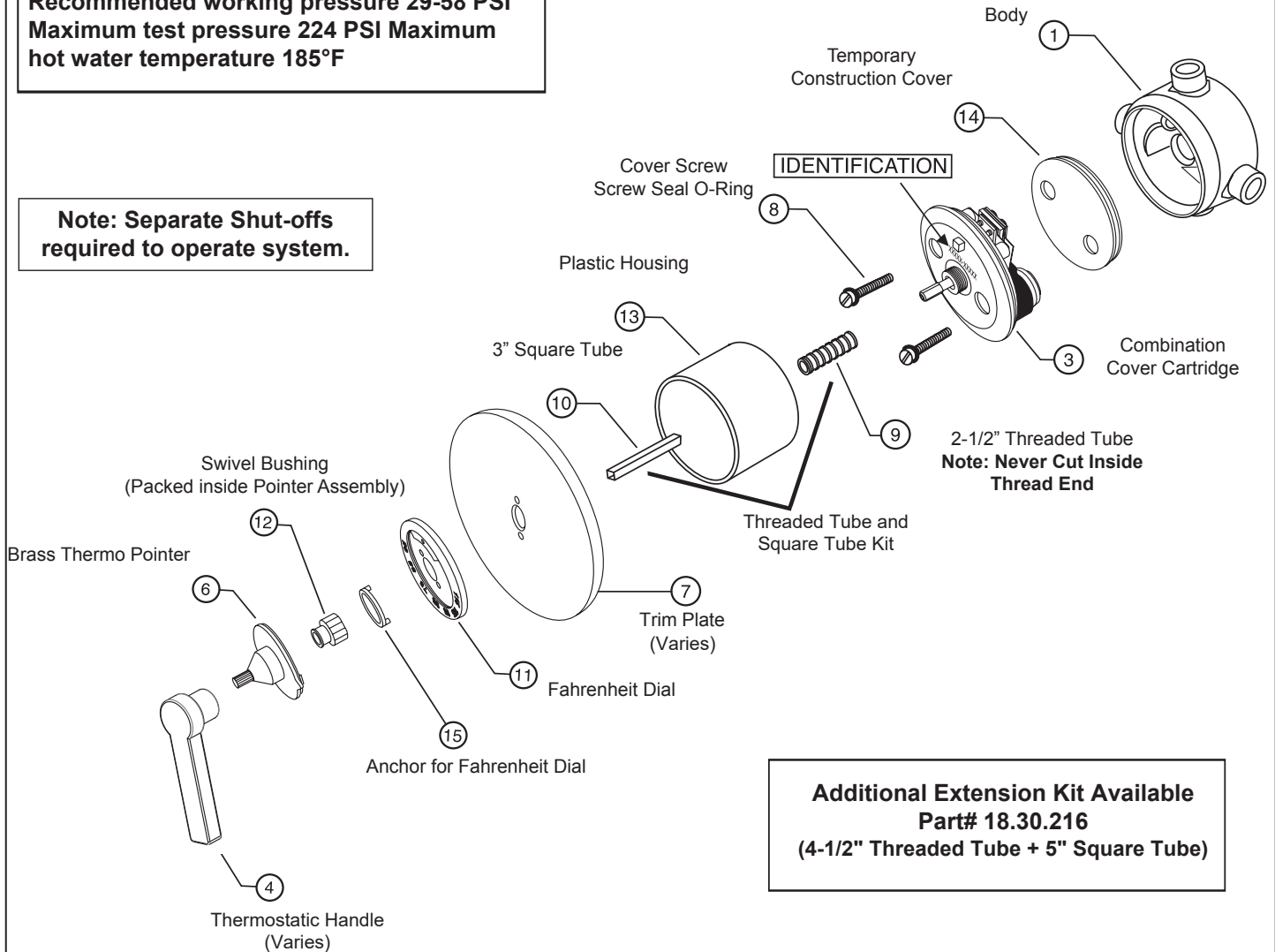

**The 1" Rough Valve is Dual Exit Ready  
Qualified contractor will use only 1" copper pipe with this valve**

**Please Note:** The valve is shipped with a temporary construction cover (14). The combination cover/cartridge (3), has been packaged separately from the valve body to prevent clogging the cartridge during installation. Install the combination cover cartridge (3) only when the hot and cold water lines are flushed and fully operational. The water heater must be working or the unit will not work.

We recommend the installation of in-line plumber supplied service stops close to the hot and cold inlets. Please remember the cartridge should be removed and cleaned annually for optimum useful life of the system.

# INSTALLATION CAUTIONS!

1. Do not attempt installation of the product if you do not understand these instructions. Qualified plumbers should be used for all installation procedures.
2. Hot and Cold inlets are clearly marked on the valve body. **Do not reverse connections, as the unit will not function properly.**
3. **NO HEAT, NO TORCH** should be applied to the valve assembly.
4. Use approved thread sealers at all joints. **DO NOT USE PLUMBERS PUTTY. THE USE OF ANY CAUSTIC MATERIAL MAY HARM THE FINISH AND/OR INTERFERE WITH PROPER FUNCTION OF THE CARTRIDGE.**
5. Prior to installing the thermostatic cartridge, flush all water lines to free up all solder, sand, silt, and debris that have loosened up from the installation process. An In-Line water filter may be recommended to remove harmful sediment.
6. Pressure or water velocity is not a function of the valve. Remember water pressure comes from your local water supplier and can be measured at the source on the street.
7. The water meter that is supplied for your home should be 25% larger than the water line supply on your recirculation loop for maximum flow rates from the valve.
8. The cartridge is activated by a Bi-Metallic strip with built-in check valves. The thermostatic cartridge should never be dismantled. Doing so will void any warranty and generally make the cartridge inoperable.
9. Minimum and maximum finished wall tolerances are clearly marked. See Pg. 3 Fig. 1
10. The plastic housing (**13**) should be kept installed even after the trim is installed for future maintenance.
11. The distance from the valve to the showerhead or other exit determines how quickly the instantaneous correction in temperature is felt.

## Technical Information

If you have lower or higher pressure than the min/max indicated on Page 1, please consult the factory representative for suggestions or solutions. The valve is completely serviceable from the front.

**Important:** All main lines must be the same size or larger than the supplied valve or the flow rates will not deliver to expectation. Therefore, if you use a 1-1/4" valve your water system should be based on a minimum 1-1/4" line--absolutely no smaller restriction should be allowed.

**Water Supply:** Sigmatherm valves can be supplied from any hot water production system, even by instantaneous domestic production, as long as the generator is capable of supplying very small quantities of hot water (about 0.8 gal/min).

### Non-Return Valves and Filters

Non-return valves are incorporated into the cartridge. Sigmatherm incorporates easily accessible stainless steel filters at the inlets of the combination cover cartridge.

However, in order to access the cartridge, we recommend the installation of in-line plumber supplied service stops close to the hot and cold inlets. Please remember the cartridge should be removed and cleaned annually for optimum useful life of the system.

# Installation Instructions

## ROUGH-IN OF VALVE

The valve comes with dual exits as a standard feature. An optional plug is provided for use if only one exit is desired. Fig. 1

1. Connect the hot water to the side with the red mark and the cold water to the side with the blue mark. Fig. 1 Install adapters at each port, seal the joint, and then run the required copper lengths to the incoming water. Solder the copper connection a minimum of 8" away from valve body. **Do not reverse the connections, as the unit will not be able to work correctly!**

2. **The plastic housing should act as a depth guide for the plumber.** Install the valve so the plastic housing extends beyond the finish wall 1/2". See wall tolerances noted in Fig. 2.

3. Cut the plastic housing flush with the FINISH wall. Fig. 2 **The plastic housing is to remain with the valve body always for maintenance reasons.**

4. Flush the supply lines completely, allowing water to pass from the hot and cold inlets through the valve body and out the outlets. The lines should be flushed long enough to remove any sediment that may come from any new additional installation such as a water heater. Failure to flush all water lines properly may damage internal parts. Supply lines **MUST** be flushed before the cartridge can be installed and calibrated.

5. The thermostatic valve only controls temperature. Shut-off valves must be provided to control water flow.

6. All valves that are not tooled with NPT connectors come with conversion adapters. (Metric and NPT)

7. For proper flow rates and multiple exit connections, call the manufacturer at 760-598-5895 and ask for Technical Support.

8. After flushing lines completely, remove and discard the temporary construction cover (14). Retain the two screws (8). Install the combination cover/cartridge (3) and secure in place using the two screws (8).

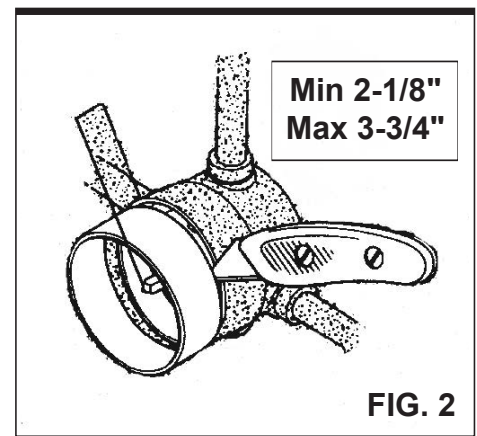
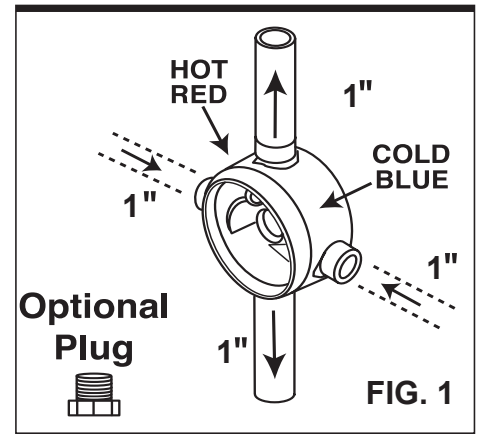

## TEMPERATURE CALIBRATION FOR THE THERMOSTATIC CARTRIDGE

We recommend the hot water heater is connected, clean, operational and set to approximately 130°-140° Fahrenheit. **If there is no hot water, valve cannot be calibrated or system tested for proper performance.**

The center cartridge affects only the mixed water temperature and must be "calibrated" to protect the end user while bathing. Calibration is simple and takes only a few additional minutes. The temperature range of mixed water is controlled through calibration, setting the hot and cold limits.

**CALIBRATION BY FEEL:** Slowly rotate the Square Tube located on the thermo cartridge all the way to the right (clockwise) to obtain the maximum cold water using a flat screwdriver inserted into the square tube. Reverse (counter-clockwise) slowly to obtain the maximum incoming hot water. Return right again (clockwise) until the mixed water at the exit point feels correct to the end user. Let water run for 2 or 3 minutes to confirm comfort level.

**BY THERMOMETER:** Slowly rotate the Square Tube located on the thermo cartridge all the way to the right (clockwise) to obtain the maximum cold water using a flat screwdriver inserted into the square tube. Reverse (counter-clockwise) slowly to obtain the maximum incoming hot water. Return again to the right (clockwise) until the mixed water at the exit point registers 105° on an instant read thermometer -- the most common temperature for adult bathing. Let water run for 2 or 3 minutes to confirm comfort level.

## Assembly

9. Fit the threaded tube (9), and tighten onto cover. Place the cover plate (7) and the dial (11) onto the threaded tube (9). Make a cutting mark 3/16" from the dial face. Fig. 3 Remove the tube and cut it, taking care not to cut inside threaded end. Debur and replace.

10. Screw the bushing (12) onto the threaded tube. (Bushing is shipped inside the pointer assembly) Slide the square tube (10) into the bushing and drive it completely onto the control spindle. Fig. 4

11. Make a cutting mark on the square tube flush with the bushing. Fig. 4 Remove the square tube, cut it, and debur carefully. Replace the tube into the bushing and push it all the way into its recess.

12. Install anchor for Fahrenheit Dial. Then install Brass Pointer with pointer facing 115°, where brass stop on dial will not allow water temperature to exceed bather's chosen temperature. Add Handle, lining up pointers and installing set screws to secure Handle to Pointer. Done!

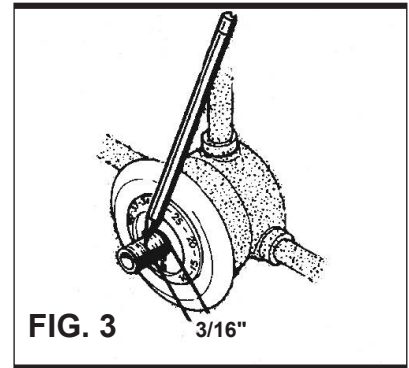

FIG. 3 3/16"

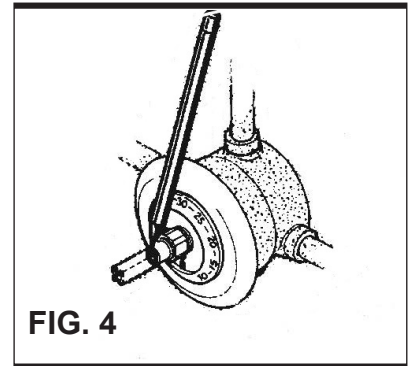

FIG. 4

## Maintenance

If the cartridge is installed prior to flushing the lines you may inadvertently clog the filters. Dirty filters may lead to a reduction in the flow rate.

It will then be necessary to remove the cartridge from the mixing valve. Soak the entire cartridge in vinegar and water solution 50/50 for 1 to 3 hours and reinstall the valve. 90% of the time the valve will then work normally.

Never take the cartridge apart, or you will void all warranties.

### Emptying in Case of Frost

When the appliance is exposed to freezing conditions it is **ESSENTIAL** to empty it:

- either by turning on a tap at the bottom outlet
- or by opening the cover (3) of the appliance.

### Cartridge Removal Guide (Future reference ONLY)

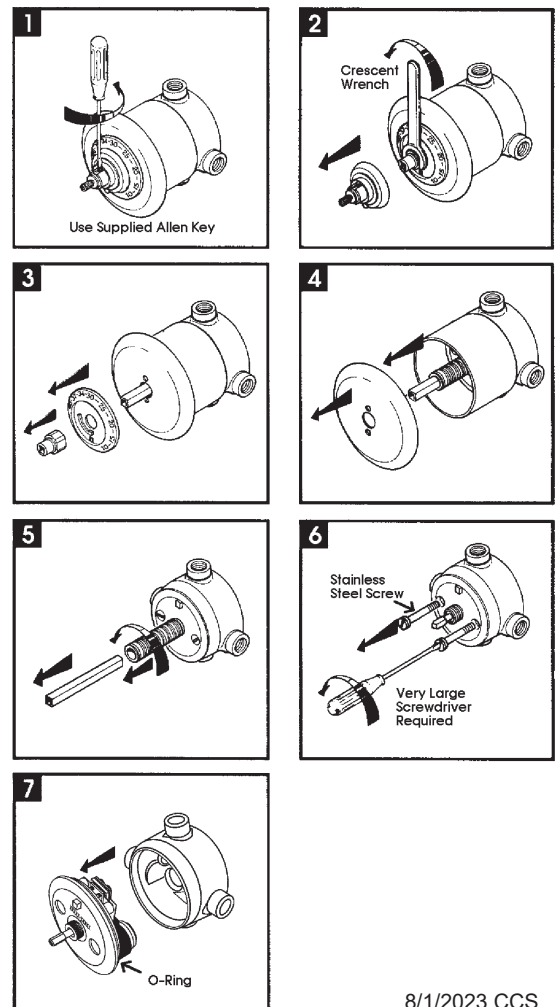

**-FULL SCALE (1:1) CUTOUT TEMPLATE-  
OR USE THE WATER/MUD GUARD AS THE ACTUAL  
CUTOUT GUIDE**

**TAKE CARE WITH WALL OPENING  
TOLERANCES ARE CLOSE**

3.75" WALL CUTOUT  
(SEE NOTE 2)

- 1. THE SOLID LINE REPRESENTS THE ACTUAL OUTLINE OF ONE OF THE TRIM PLATES (ROUND TRADITIONAL) FOR VISUAL REFERENCE
- 2. THE DASHED LINE REPRESENTS THE TYPICAL WALL CUTOUT NECESSARY FOR THERMOSTATIC VALVE MAINTENANCE.

THE VALVE COMES WITH A WATER CONTROL RING!  
THIS MUD GUARD RING IS PART OF THE INSTALLED ROUGH VALVE. THIS GUARD MUST REMAIN WITH THE VALVE AND THE INSTALLED APPLICATION.  
THIS GUARD PREVENTS WATER FROM FLOWING INTO THE WALL WHEN THE COVER IS REMOVED TO SERVICE THE THERMOSTATIC CARTRIDGE.

PLATE →

- NOTES:
- 1. THE SOLID LINE REPRESENTS THE ACTUAL OUTLINE OF THE TRIM PLATE.
  - 2. FOLLOW INSTRUCTIONS ON MUD GUARD FOR CUT OUTS AND INSTALLATION DEPTH.

**LEAVE ON JOBSITE FOR TILE / MARBLE CONTRACTOR**

## TROUBLE-SHOOTING THE 1" THERMOSTATIC VALVE

In the event of an operating problem, review the following information. Make sure hot and cold inlets are correctly connected to the marked hot and cold side of the valve body. Be sure there is sufficient water pressure and that you have calibrated the cartridge correctly. Check whether the screens are clean of debris. The main operating problems and their causes are described below. If the problem is caused by the valve, contact your authorized dealer for a return request

<u>OPERATING DEFECTS</u>	<u>REASON</u>
1. When first using a new appliance, only hot or cold water is delivered.	<ul style="list-style-type: none"> <li>- The water inlets are reversed.</li> <li>- The bi-metal strip is not properly centered.</li> <li>- The distributing valve is not free.</li> </ul>
2. The mixed water temperature follows the position of the graduated regulator but with a certain delay.	<ul style="list-style-type: none"> <li>- The cartridge is incorrectly calibrated.</li> </ul>
3. The appliance does not deliver mixed water or only when the regulator is turned up all the way.	<ul style="list-style-type: none"> <li>- One of the water inlets doesn't work.</li> </ul>
4. The mixed water is delivered in spurts and the flow rate is low except at one temperature or the limited temperature.	<ul style="list-style-type: none"> <li>- One of the water supplies doesn't provide sufficient water.</li> </ul>
5. From time to time the appliance only delivers hot or cold water.	<ul style="list-style-type: none"> <li>- The bi-metal strip is not properly centered.</li> <li>- The distributing valve is not free.</li> </ul>
6. The water is always supplied at the same temperature hot or cold.	<ul style="list-style-type: none"> <li>- The bi-metal strip does not move the distributing valve</li> <li>a) Because the distributing valve is not free.</li> <li>b) Because the regulating screw does not act on the mechanism.</li> <li>c) Because the cartridge is incorrectly calibrated</li> </ul>
7. The temperature is irregular, especially when flow rates are low.	<ul style="list-style-type: none"> <li>- There are foreign particles beneath the filter.</li> <li>- The filter is damaged.</li> </ul>
8. Insufficient mixed water is supplied.	<ul style="list-style-type: none"> <li>- Pressure is too low.</li> <li>- One or both of the water supplies is insufficient.</li> </ul>

**Product/Finish Warranty:** American Faucet & Coatings Corporation warrants that products are free from defects in materials and workmanship for five (5) years from date of invoice. In addition, our Finish Warranty provides limited LIFETIME coverage for Chrome & PVD finishes, five (5) years for Omega powder coated finishes. Living finishes are war-ranted for workmanship only. If any material proves to be defective after inspection by our company, it will be repaired or replaced at our discretion at no charge. However, no claims for labor, shipping costs, or consequential damages will be accepted.

**What we will do:** We will restore any product whose finish proves to be defective back to its original finish at no charge during the appropriate warranty period stated above. Proof of purchase must be provided. After the warranty period, American Faucet and Coatings Corporation will refinish any of its faucets at the prevailing appropriate charge.

**What you must do:** The faucets must be properly installed according to our instructions and specifications & are for residential use only. The faucets cannot be altered in any way. You must maintain and clean the faucets in accordance with the instructions provided with the product. You must use the faucet(s) for residential use only.

**How to obtain service:** Contact our customer service by calling 800.960.BATH or send an email to customerservice@sigmafaucet.com. Please have you model number and proof of purchase available so we can better assist you.

We will then respond and take appropriate action. Do not send us any part(s) of your faucet(s) or its various connecting hoses unless we have contacted you and have sent you an approved RGA form. All transportation charges for returned goods must be paid by the customer.

**What is not covered:** This warranty does not cover the crystal/glass, or porcelain products of any faucet or the drain assembly or aerator on other than the Chrome or PVD finishes. This warranty also does not cover damage caused by accident, alterations, misuse, abuse, normal wear and tear, lime deposits, direct exposure to salty air or corrosive materials, or the color change that takes place with the passage of time, or use in any manner contrary to American Faucet and Coatings Corporation's printed instructions. In the case of in-the-wall installations American Faucet and Coatings Corp. will assume no liability if there is no access. **In no event will we be liable for labor of any kind, incidental or consequential damages.** This warranty is extended in lieu of all other expressed or implied warranties, whether oral or written. **Many installation compounds are harmful to brass and metal finishes. The use of any lead-based or acidic curing adhesive, silicone, mastic, or plumber's putty on or near our finished products will void the finish warranty. Use only sealants which are neutral curing and are not reactive with metal and brass finishes.** American Faucet & Coatings Corporation reserves the right to change, modify or alter its products as deemed necessary. This warranty super-sedes any other American Faucet & Coatings Corporation warranties, whether oral or written.

*Unless otherwise contrary to state law governing the purchase, American Faucet and Coatings Corporation's liability will not exceed the wholesale price for the American Faucet and Coatings Corporation product considered defective. This warranty gives you specific legal rights, and you may also have other rights which vary from state to state. Some states do not allow exclusion of incidental or consequential damages, so the above limitation may not apply to you.*

#### LIFETIME WARRANTY ON 1/4 TURN CERAMIC DISC CARTRIDGE

Should the ceramic disc cartridge in your faucet ever fail, American Faucet & Coatings Corporation will replace the failed part free of charge to the original purchaser of the product. Shipping and handling charges will apply. Labor not included. When ordering replacements, denote for widespread or centerset lavatory, Roman Tub, or other. Include age of faucet. (This does not include thermostatic, pressure balance, or diverter cartridges.)

#### CONSUMER WARNING CALIFORNIA PROPOSTION 65 WARNING

Among other chemicals known to cause harm, this faucet contains lead, a chemical known to the State of California to cause birth defects or other reproductive harm.

All faucets and products made of leaded brass alloys, even those that comply with U.S. Environmental Protection Agency regulations, contribute small amounts of lead to water that is allowed to stand in contact with the brass. This faucet complies with all E.P.A. regulations regarding the amount of lead used in plumbing brass and solder. The amount of lead contributed by any faucet is highest when the faucet is new. The following steps will reduce potential for exposure to lead from faucets and other parts of the plumbing system:

- Always run the water for a few seconds prior to use for drinking or cooking.
- Use only cold water for drinking or cooking.
- If you wish to flush the entire plumbing system of water that has been standing in the pipes or other fittings, run the cold water until the temperature of the water drops, indicating water coming from the outside main.
- If you are concerned about lead in your water, have your water tested.