



Installation Instructions for 1/2" Thermostatic Valve

with Volume Control
P/N: 78.30.079

NEW FORGED BODY



2-17-06 (CIRCA) 0 VOLUME AS SHOWN

Please read the complete thermostatic instructions and cautions contained in this booklet before attempting installation. It is recommended that only a licensed, professional plumber install this product. Leave booklet for homeowner's future reference.

FEATURES:

- Convenient, complete serviceability from front of unit.
- 3/4" NPT inlets provide for less restriction of incoming water.
- 5.0 gpm @ 56 psi when both exits are used.
- Screw driver spring loaded stops are used for integral service shut-offs.
- Extension kits are available through dealer at an extra charge.
Request the following:
18.30.216, containing: 4-1/2" Threaded Tube
5" Square Tube
- The parafin wax sensitivity cartridge constantly monitors temperature and re-adjusts within 2 ° Fahrenheit of set temperature when supply pressure and/or temperature fluctuates. Re-adjustment occurs in less than 2 to 4 seconds.
- 1/2" valve offers up to 2 built-in exits as a standard feature. You may decide to use separate shut-offs.

CARE INSTRUCTIONS:

The product you have just purchased is designed to provide long lasting beauty and dependability. When installing, we recommend you lay all finished parts on a soft cloth or towel to avoid scratching or damaging the product. To insure your product's longevity, wipe with a clean, soft, damp cloth and blot dry as often as possible. Never use abrasive cleansers, sponges, or acidic cleaning products as these may damage the finish and may VOID THE WARRANTY.

INSTALLATION INSTRUCTIONS

1/2" THERMOSTATIC VALVE & SYSTEMS

CAUTIONS !



NO HEAT, NO TORCH ... Shall be applied to the valve assembly. Cartridge and ceramic seats cannot withstand heat from soldering torch.



Use teflon tape thread sealer at all joints. **DO NOT USE PLUMBERS PUTTY. USE OF ANY CAUSTIC MATERIAL MAY HARM THE FINISH AND/OR INTERFERE WITH PROPER FUNCTION OF THE CARTRIDGE.**



Prior to installing the thermostatic valve, flush all water lines to free up all solder, sand, silt and debris that have accumulated in plumbing lines. The lines should be flushed long enough to remove any sediment that may come from any new additional installation such as a water heater.

Reminders Prior to Starting:

- Water pressure comes from your local water supplier and can be measured at the source on the street. Pressure or water velocity is not a function of the valve.
- Keep in mind the distance the shower head or other exit is from the valve will affect how quickly you feel the instantaneous correction in the temperature.
- Water heater must be operational for valve to function.
- Failure to flush all water lines properly as stated above may damage internal parts.
- Serviceable spring check valves are provided with the valve and may be blocked by initial failure to flush lines or by heavy sediment. An in-line water filter may be recommended in certain situations such as well water.
- For proper flow rates and custom, multiple exit installations, check with your authorized dealer for installation assistance. When incorporating body sprays into a system, no more than three sprays should be plumbed out of the top outlet only for maximum flow in conjunction with a pressure balancing loop.
- Do not attempt installation of the product if you do not understand these instructions.
- Qualified plumbers should be used for all installation procedures.

Begin Installation:

STEP 1 Read complete instructions and prints from start to finish before beginning



REMEMBER NO HEAT NO TORCH APPLIED DIRECTLY TO VALVE!!

STEP 2 Install male adapters at inlets with the required length of copper pipe (minimum 8") already soldered to the adapter. Then connect the hot water to the side stamped with + (plus) and the cold water to the side stamped - (cold). **DO NOT REVERSE CONNECTIONS** : the valve will not work properly! The screw driver integral stops are 1/4 turn ceramic disc cartridges. Any debris caught in the cartridge discs may cause exits to drip.

- STEP 3** The depth of the valve should be determined using mud guard. (PRINT #4) Square tube will then be 1-1/2" from finished wall. If square tube should extend beyond 1-1/2" then metric tube and square tube may be cut. NOTE: Metric all-thread tube (Print #1) has threads on inside. DO NOT CUT THIS END. Extensions are available for an extra charge through dealer as previously noted.
- STEP 4** Connect the exit(s) required to copper pipe using same precautions mentioned in Step #2. NO HEAT, NO TORCH!
- STEP 5** If needed, remove cartridge by rotating counter-clockwise before removing (PRINT #5) and flush lines one last time. Replace cartridge, pushing straight into body and rotating clockwise until tight. Replace the cartridge holding nut, threaded tube, and square tube. (PRINT #1) Open both screwdriver inlet ports and pressure test all connections with water. Check for flow and leaks before closing wall. Wall cut-out should follow mud guard. (PRINT #6)
- STEP 6** Be sure hot water heater is connected, clean and operational and set to approximately 140° degrees Fahrenheit. If there is no hot water, valve cannot be calibrated or system tested for proper performance. Install plate, dial, temperature limit stop, swivel bushing, square tube and metric tube. Not the handle trim. The valve is now ready for temperature adjustment. SEE PRINT #1
- STEP 7** The valve cartridge affects only the mixed water temperature and must be "calibrated" to protect the end user while bathing. (Valve requires separate shut-offs to control volume.) Calibration is simple and takes only a few additional minutes. The temperature range of mixed water is controlled through calibration, setting the hot and cold limits.



CALIBRATION OF VALVE PROVIDES SAFETY TO END USER.
PLEASE READ CAREFULLY

CALIBRATION BY FEEL: Rotate the Swivel Bushing with Square Tube located on the Thermo Cartridge (Print #1) all the way to the right (clockwise) to obtain the maximum cold water using either a flat screwdriver inserted into the square tube or wrench on the swivel bushing. Reverse (counter-clockwise) to obtain the maximum incoming hot water. Return right again (clockwise) until the mixed water at the exit point feels correct to the end user. Let water run for 2 or 3 minutes to confirm comfort level. Set the pointer dial at the chosen mark on the dial and carefully fix the set screw. You should set pointer at 95° minimum or you could burn yourself with the hot water.

BY THERMOMETER: Rotate the Swivel Bushing with Square Tube located on the Thermo Cartridge (Print #1) all the way to the right (clockwise) to obtain the maximum cold water using either a flat screwdriver inserted into the Square Tube or a wrench on the Swivel Bushing. Reverse (counter-clockwise) to obtain the maximum incoming hot water. Return again to the right (clockwise) until the mixed water at the exit point registers a recommended 100° degrees on an instant read thermometer. Let water run for 2 or 3 minutes to confirm comfort level. Set the pointer dial at the 100° mark on the dial and carefully fix the set screw. After installing other system trim parts, valve is ready to enjoy. SEE PRINT #1 TYPICAL TRIM DETAIL

Maintenance:

Occasionally, remove cartridge and brush debris and hard water build-up on outside of cartridge with a toothbrush. It may be necessary to soak cartridge in a 50/50 solution of clear household vinegar and water to remove tough deposits. Never take the thermostatic cartridge itself apart. Doing so will damage this precise instrument, generally make the cartridge inoperable, and void any warranty. Frequency of maintenance varies with many factors, such as mineral content (hardness) of water supply, new construction/changes affecting any home water lines, age of property, use of well water, etc.



1/2" FULL-FLOW THERMOSTATIC VALVE INSTRUCTIONS

1/2" FULL-FLOW EXPLODED VIEW

**EXPLODED VIEW
PRINT 1**

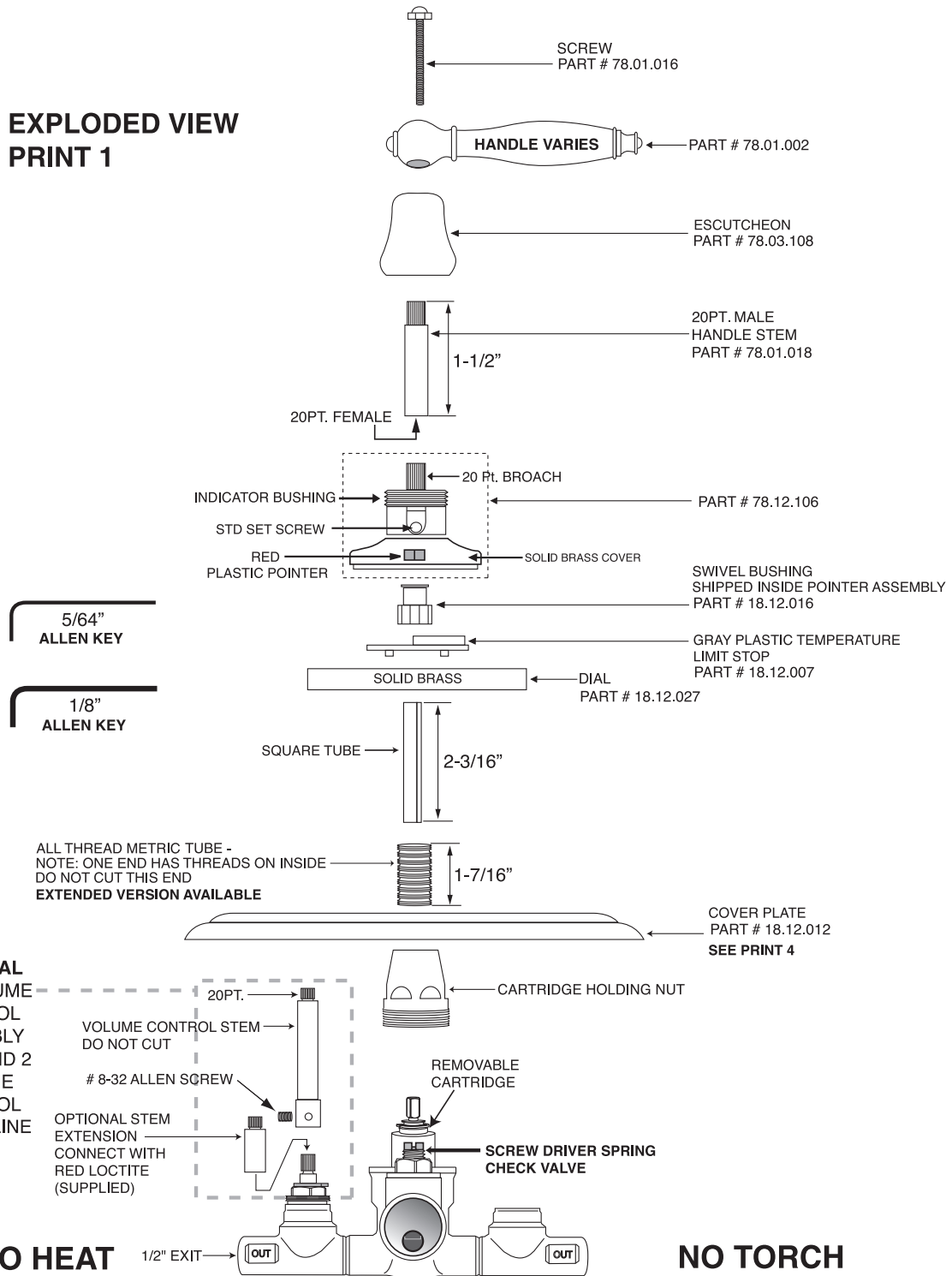

Thermostatic Valve

PRINT 2

THERMOSTATIC VALVE

PROFILE VIEW OF INSTALLED ROUGH VALVE ONLY
1/2" FULL FLOW VALVE AVAILABLE WITH SINGLE OR DUAL EXITS

SEE PRINT 4 ROUGH VALVE INSTALLATION PROCEDURE

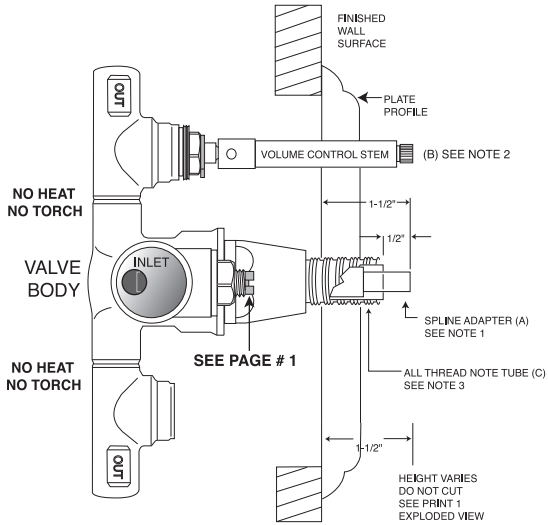

INSTALLER NOTES: THIS VALVE MUST BE INSTALLED AS SHOWN ABOVE

(1) FROM THE FINISHED WALL TO THE END OF THE SPLINE ADAPTER (A) ALLOW 1-1/2" - PART SHOULD NOT BE CUT - EXTENSIONS ARE AVAILABLE.
THIS SQUARE TUBE IS SHIPPED WITH THE TRIM

(2) VOLUME CONTROL STEM (B) CANNOT BE CUT - WE HAVE EXTENSIONS IF VALVE BURIED TOO DEEP.

PRINT 3

THERMOSTATIC VALVE

1/2" FULL FLOW WITH DUAL EXITS

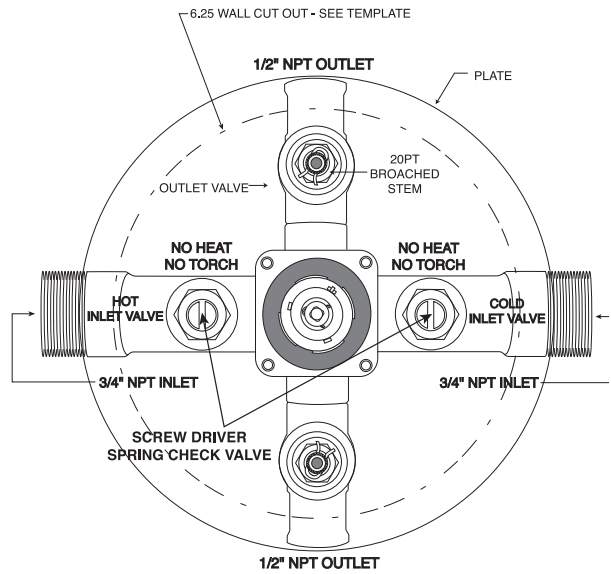

NOT A TEMPLATE DO NOT SCALE DRAWING

NO HEAT
NO TORCH

FACTORY
TESTED AND
SEALED

PRINT 5

THERMOSTATIC 1/2" CARTRIDGE REMOVABLE FROM THE TOP

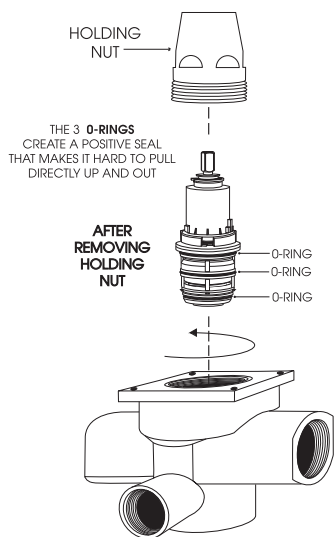

TO REMOVE CARTRIDGE FROM BODY:
ROTATE CARTRIDGE COUNTER CLOCKWISE ONLY

TO RE-SET: (RE-SEAL - PUSH STRAIGHT INTO
BODY AND SECURE WITH HOLDING NUT)

PRINT 6

INSTALLATION AND PROPER ALIGNMENT OF CARTRIDGE FOR 2 EXIT BALANCED TEMPERATURE CONTROL

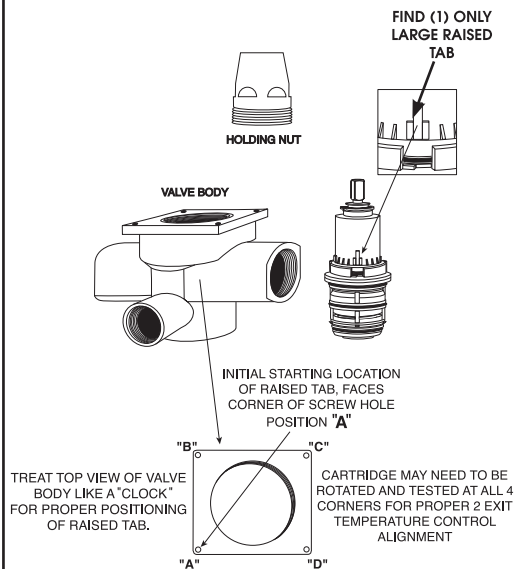

PRINT 7

SPRING CHECK VALVE

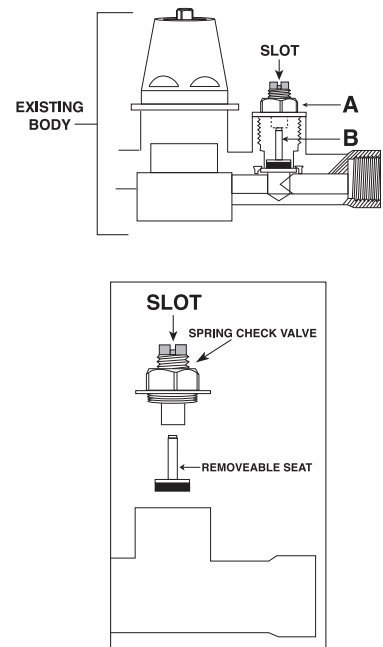

THERMOSTATIC VALVE

-FULL SCALE (1:1) CUTOUT TEMPLATE

FOR 1/2" FULL FLOW SYSTEMS

**COVER PLATE
PRINT 4**

PLATE
(SEE NOTE 1)

ACTUAL MUD GUARD TO SCALE

**ROUGH VALVE TO BE
INSTALLED
USING BLACK
MUD GUARD INSTRUCTIONS**

**BLACK
MUD
GUARD**

NOTES:

1. THE SOLID LINE REPRESENTS THE ACTUAL OUTLINE OF THE TRIM PLATE.
2. FOLLOW INSTRUCTIONS ON MUD GUARD FOR CUT OUTS AND INSTALLATION DEPTH.