

Replacement thermostatic cartridge: 18.30.082  
Screw driver spring check valve: [2] 18.30.181  
Flow rate: 14.5 GPM at 45 PSI (9.5 GPM top exit)  
Note: Separate shut-offs required to operate system

## 1/2" Thermostatic Valve

### 18.30.078

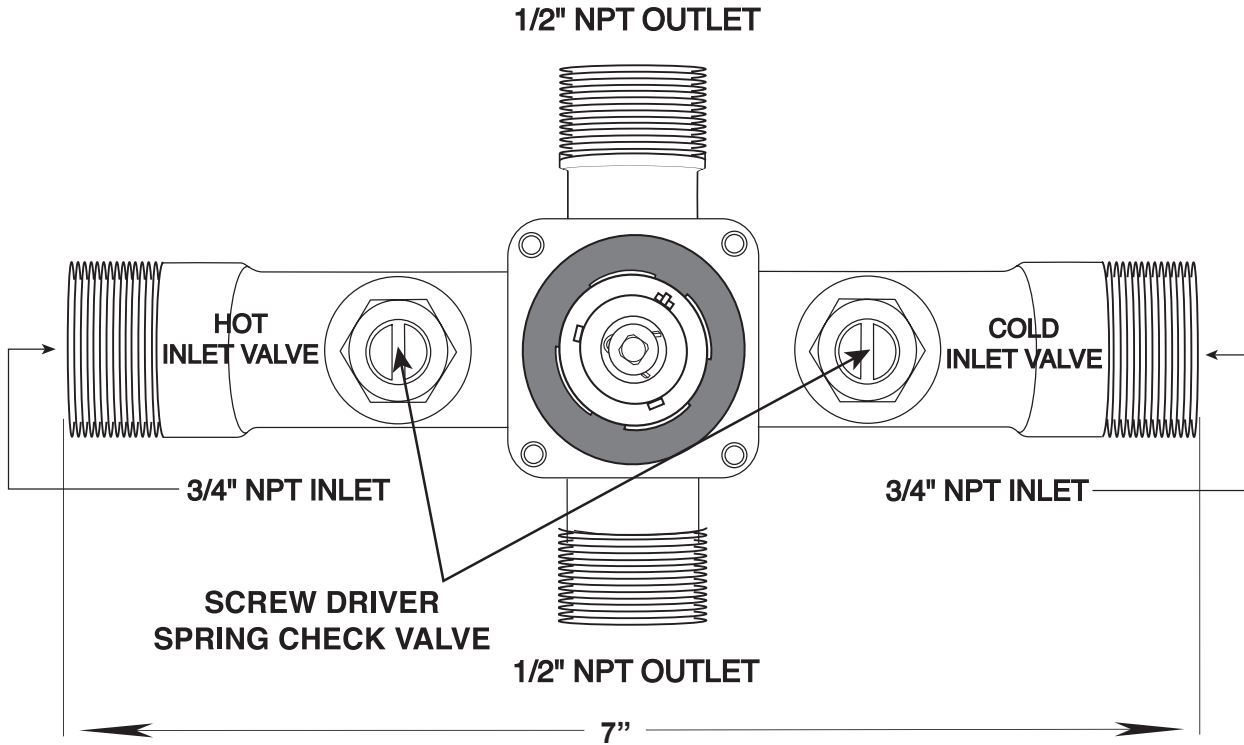

### SIDE VIEW

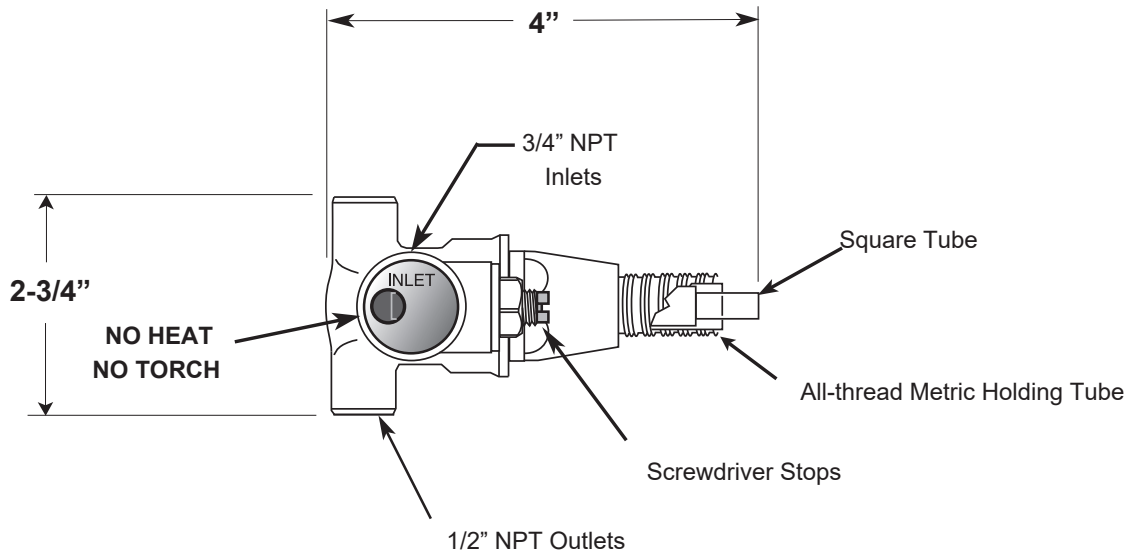

Note: Measurements are subject to change or cancellation. No responsibility is assumed for use of superseded or voided pages.