

Features:

- Forged brass construction
- Built-in diverter valve assembly
- 8" Center to Center available on request
- Replacement cartridge: 18.30.035 - cold / 18.30.036 - hot
18.30.012 - diverter
- Includes 1.8 GPM Showerhead (18.10.024), arm & flange
- 3200 Wall Tub Spout 18.17.027 and spout ring

3 Valve Tub & Shower

1.324133D

Georgian Handle

1.324133DT Trim Only

Top View

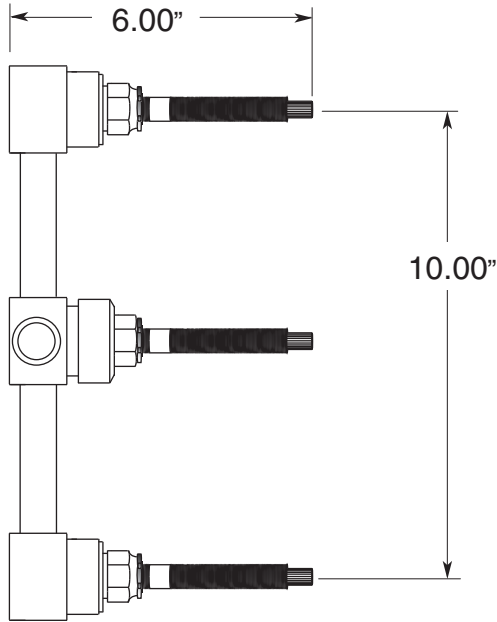

Side View

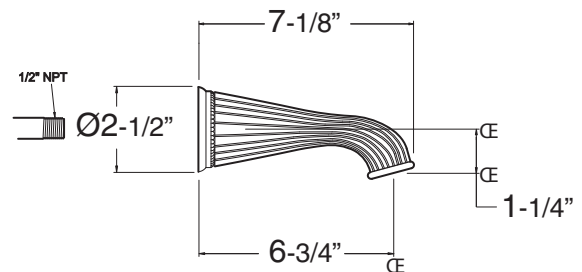
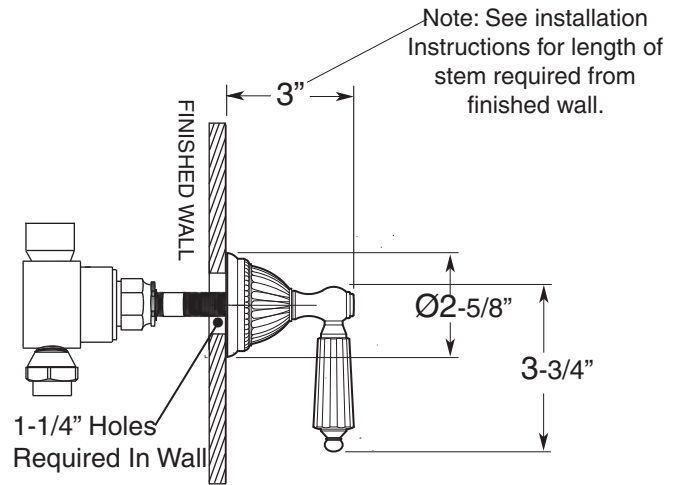
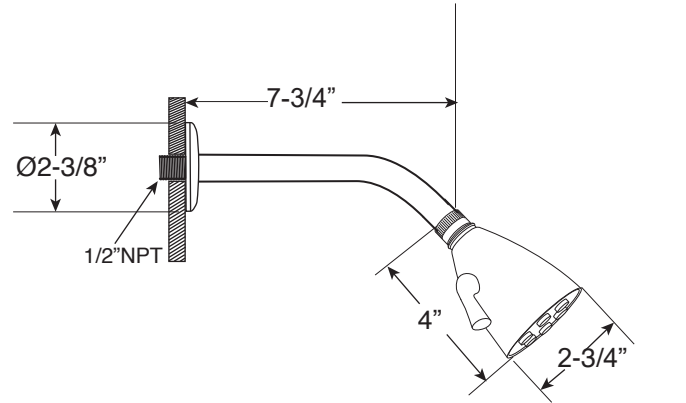
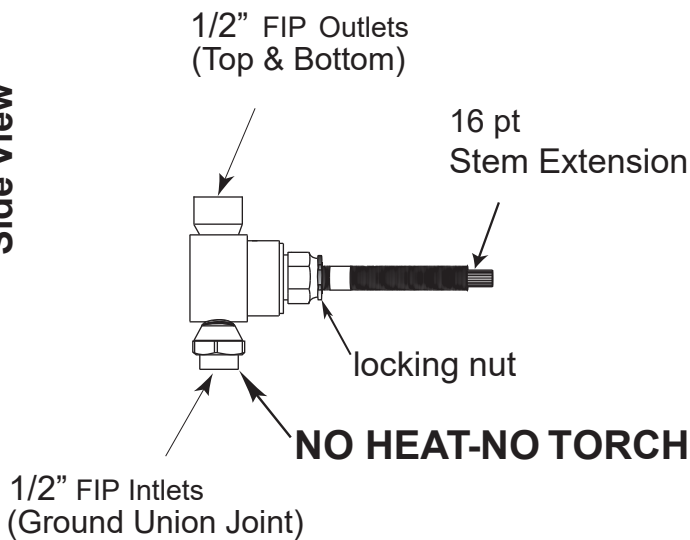

Note: Measurements are subject to change or cancellation. No responsibility is assumed for use of superseded or voided pages.