

Series 110

Pressure Balanced Tub & Shower

Stella X Handle
1.110868

Features:

- Forged brass construction
- Ceramic disk valve cartridge 18.30.865
- Adjustable hot limit safety stop
- Reversible cartridge
- 5.6 GPM @ 45 PSI

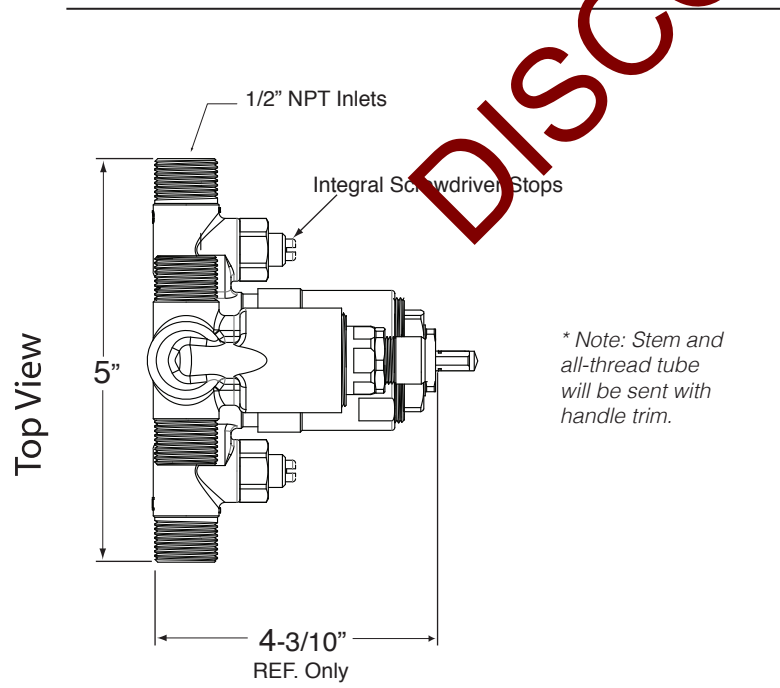
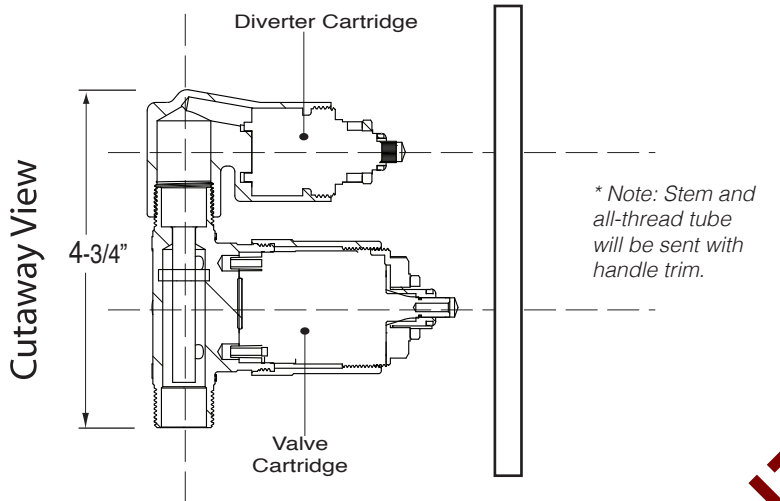

(1.110868T - Trim Only)

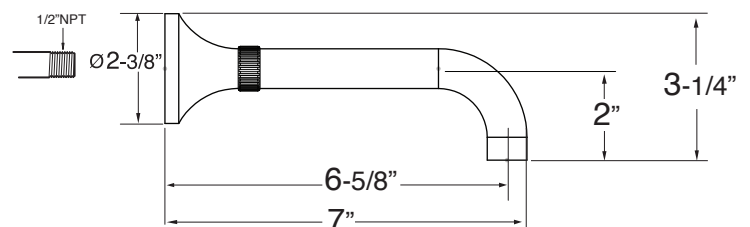
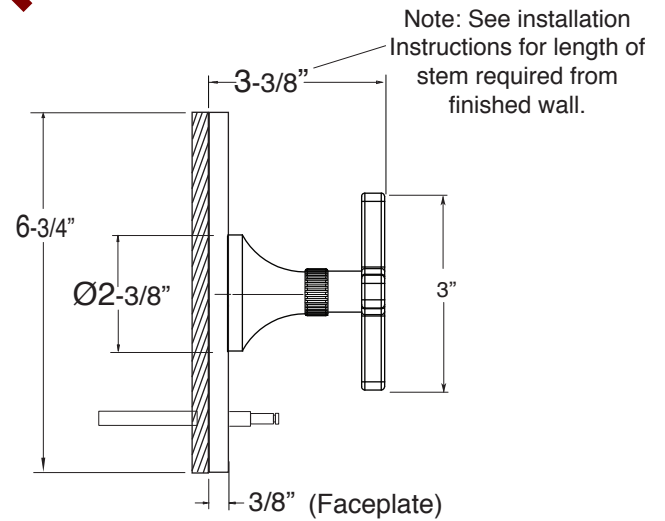
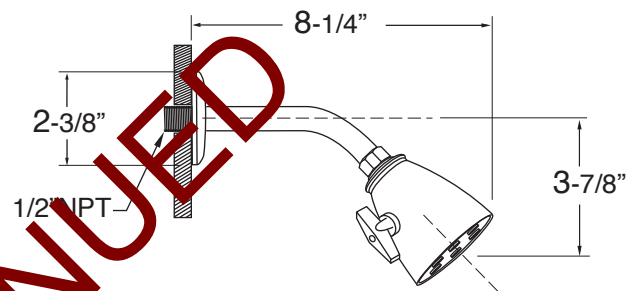

Note: Measurements are subject to change or cancellation. No responsibility is assumed for use of superseded or voided pages.