

TechData
SPECIFICATIONS
Series 1500
Pressure Balance Tub & Shower
1.152768
Huntington Handle
(1.152768T - Trim Only)

Features:

- Forged brass construction
- Ceramic disk valve cartridge 18.30.865
- Adjustable hot limit safety stop
- Reversible cartridge
- 5.6 GPM @ 45 PSI

Cutaway View

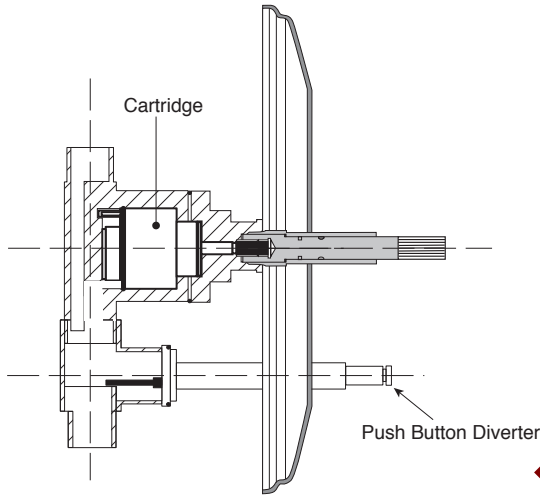

Top View

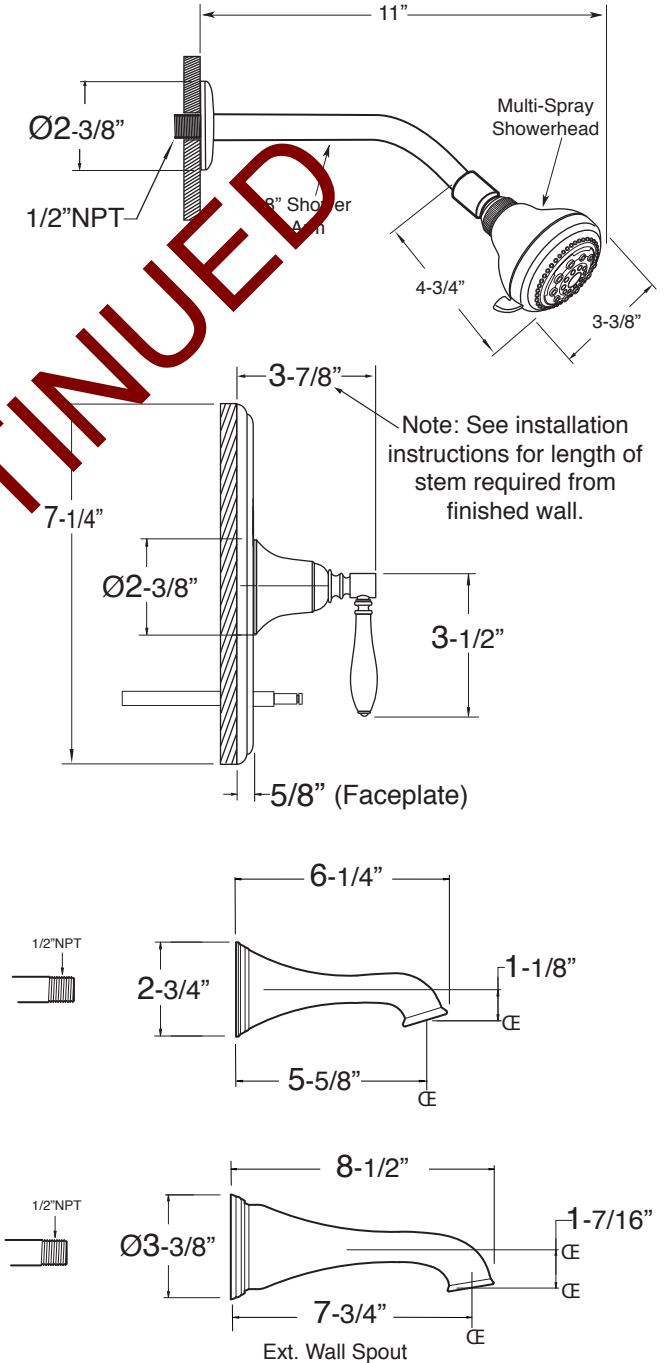
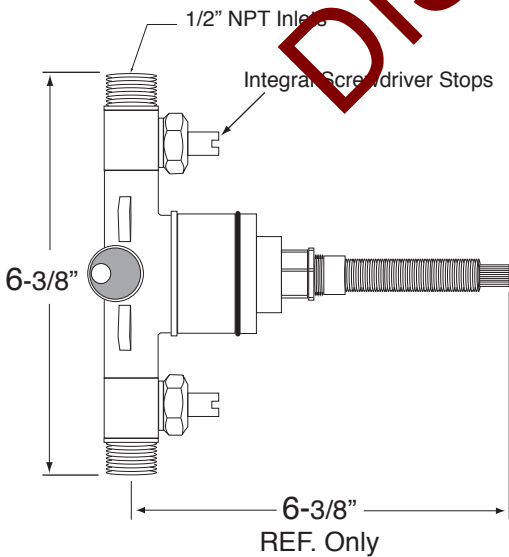

Note: Measurements are subject to change or cancellation. No responsibility is assumed for use of superseded or voided pages.