

Features:

- Forged brass construction
- Built-in diverter valve assembly
- 8" Center to Center available on request
- Replacement cartridge: 18.30.035 - cold / 18.30.036 - hot  
18.30.012 - diverter
- Includes 1.8 GPM Showerhead (18.10.051), arm & flange
- 200 Wall Tub Spout (18.17.001) and spout ring

**3 Valve Tub & Shower**

1.201333

Hampshire Handle

1.201333T Trim Only

Side View

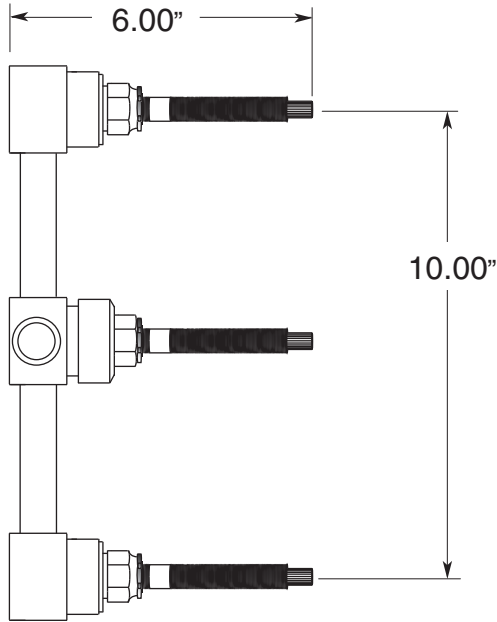

Side View

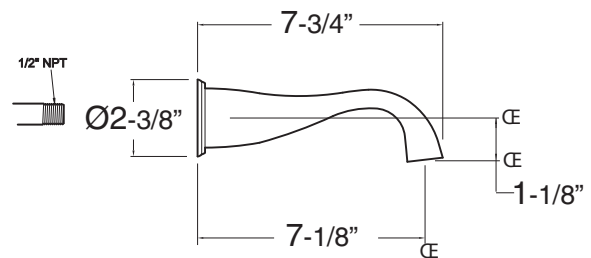
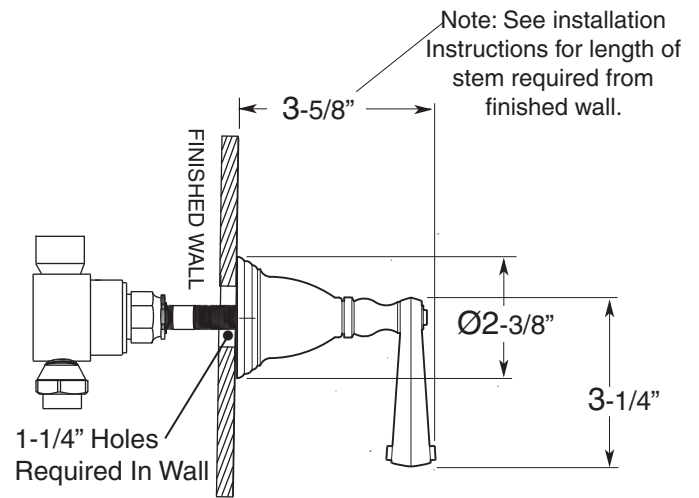
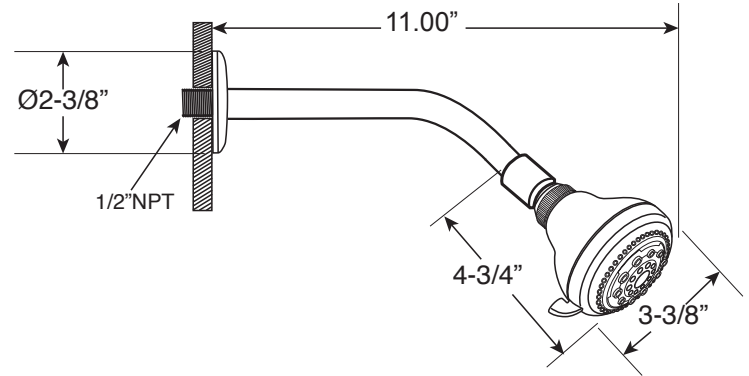
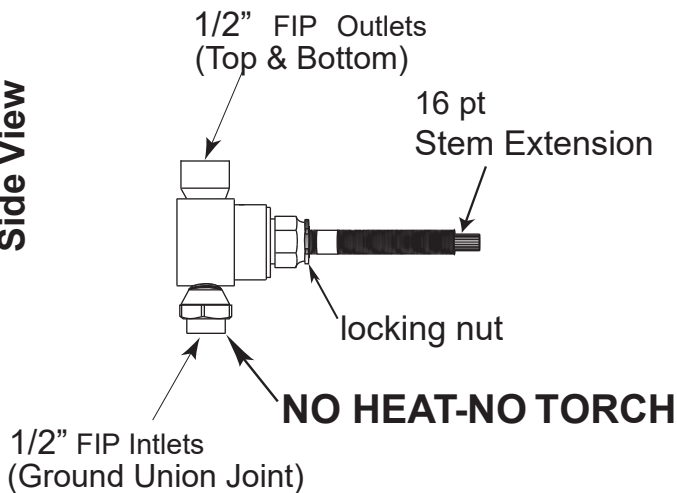

Note: Measurements are subject to change or cancellation. No responsibility is assumed for use of superseded or voided pages.