

**FEATURES:**

- Forged brass construction.
- Thermostatic valve cartridge: 18.30.082
- Screw driver spring check valve: (2) 18.30.181
- 14.5 GPM @ 45PSI (9.5 top exit)

Note: Separate shut-offs required to operate system.

1/2" Thermostatic Shower Set  
without Volume Control with  
Nova II Handle

1.074896.V0

(1.074896.V0T Trim Only)

**SIDE VIEW - INSTALLED**

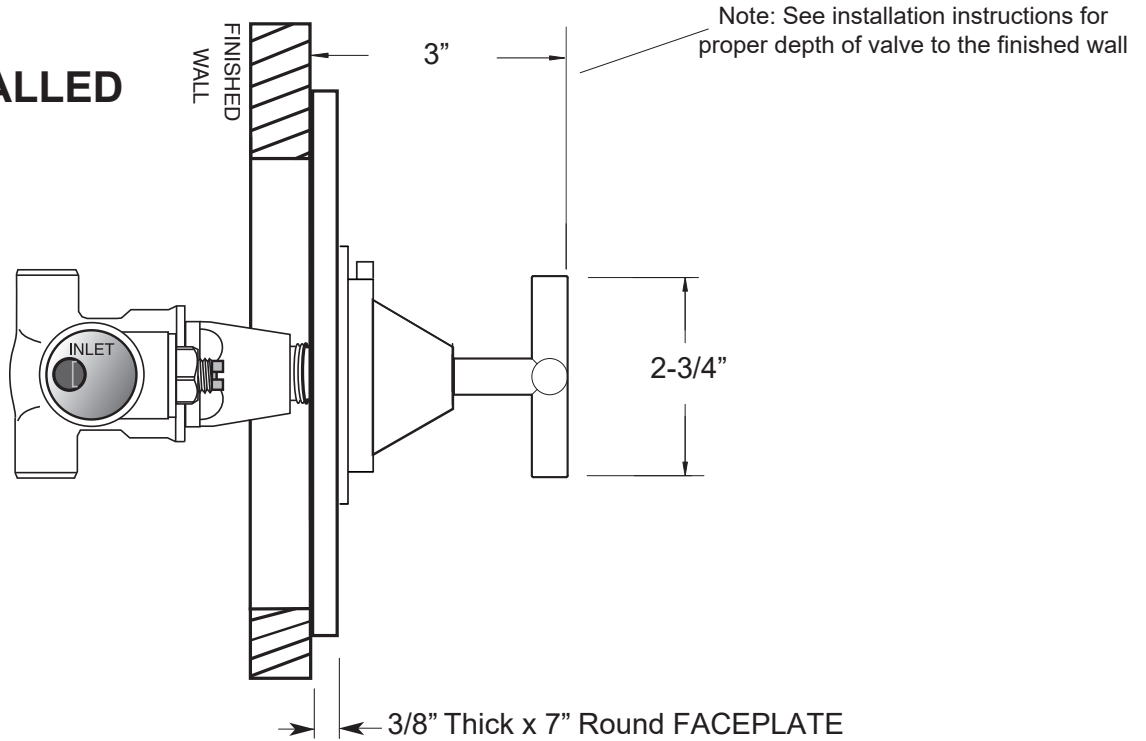

**SIDE VIEW - VALVE ONLY**

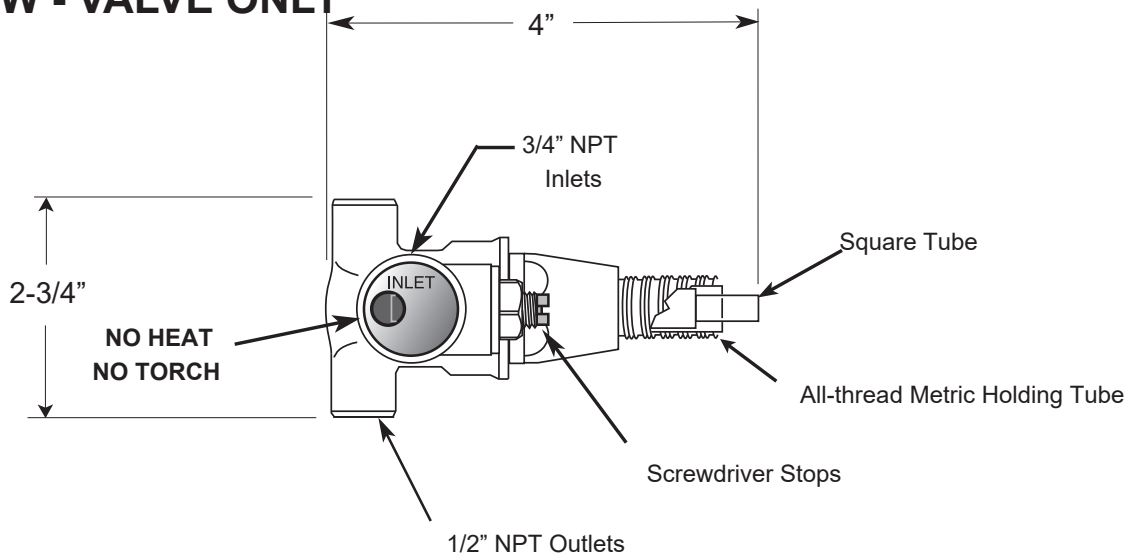

Note: Measurements are subject to change or cancellation. No responsibility is assumed for use of superseded or voided pages.