

Series 620

Pressure Balance Shower by Shower Set

1.009467

(1.009467T - Trim Only)

Moderne X Handle

16 pt.

**FEATURES:**

- Forged brass construction
- Valve cartridge 18.30.893
- Diverter cartridge: 18.30.898
- Adjustable hot limit safety stop
- Reversible cartridge
- 4.5 GPM @ 45 PSI



**FRONT VIEW**

**SIDE VIEW**

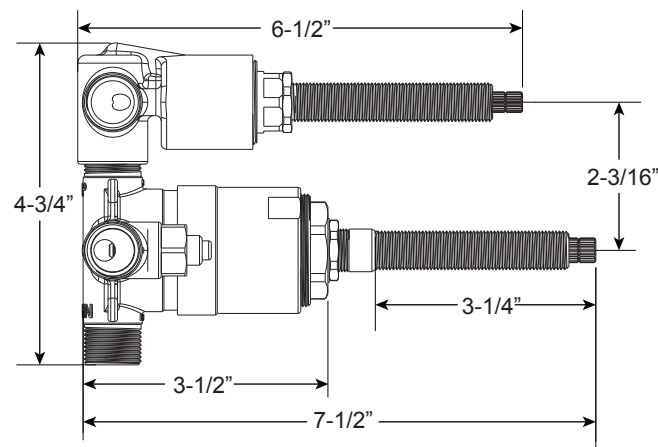

*\*Note: Stem and all-thread tube will be sent with handle trim.*

**Please Note:**

*Must purchase the two desired shower components separately. See current catalog for shower component options.*

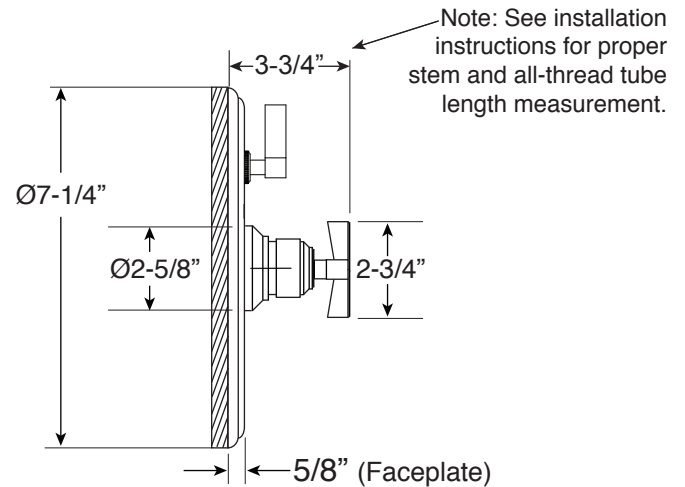

Note: See installation instructions for proper stem and all-thread tube length measurement.

\* Current valve in use:  
Circa 4/2014 - present  
Contact Customer Service  
for Older Versions

\*\* For additional information on  
cartridges or extension kits,  
see 'Rough Valving' section  
in current catalog.

Note: Measurements are subject to change. No responsibility is assumed for use of superseded or voided pages.