

Features:

- Forged brass construction
- 8" Center to Center valve (18.30.008)
- 10" Center to Center valve available on request (18.30.141)
- Replacement ceramic disc cartridge:  
COLD 18.30.035 / HOT 18.30.036
- Includes 1.8 GPM Showerhead (18.10.051), arm & flange

**2 Valve Shower Set**

8" Spread

1.000542

Charlotte Elite Handle

(1.000542T Trim Only)

**Top View**

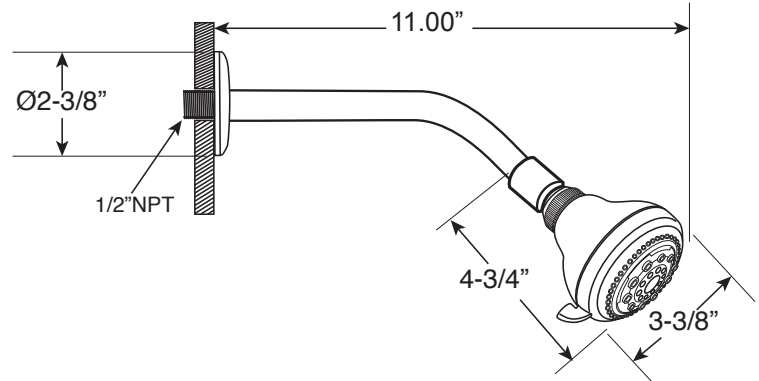
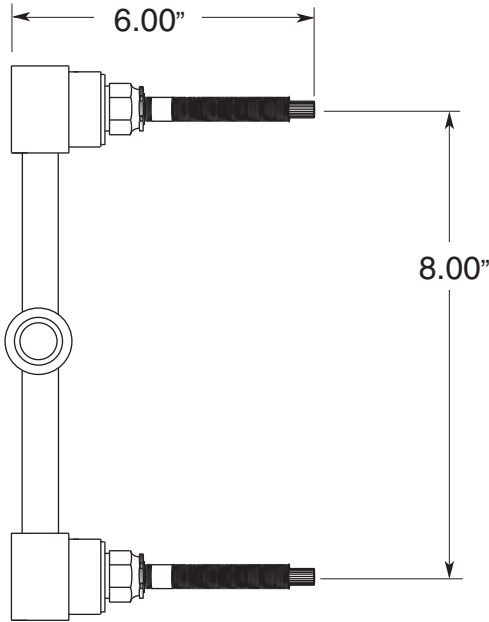

**Side View**

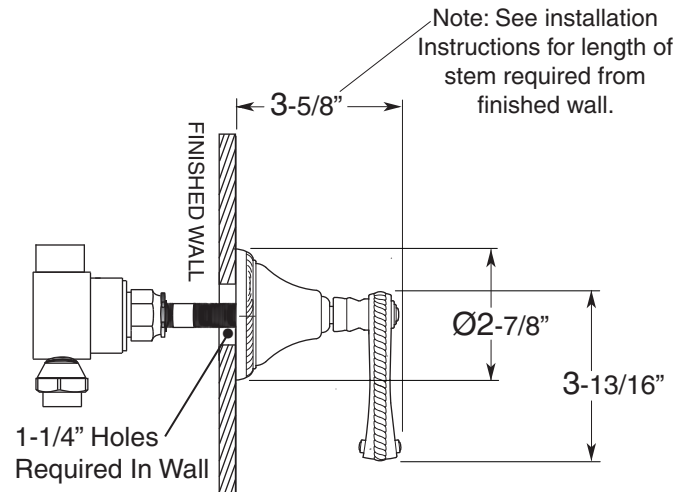
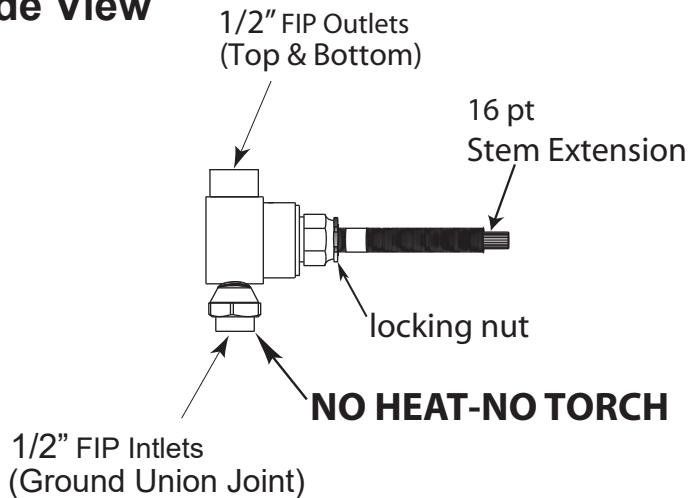

Note: Measurements are subject to change or cancellation. No responsibility is assumed for use of superseded or voided pages.