

FEATURES:

- Forged brass construction.
- Thermostatic valve cartridge: 18.30.082
- Screw driver spring check valve: (2) 18.30.181
- 14.5 GPM @ 45PSI (9.5 top exit)

Note: Separate shut-offs required to operate system.

**1/2" Thermostatic Shower Set
without Volume Control with
Chicago Handle
1.008596.V0**

(1.008596.V0T Trim Only)

SIDE VIEW - INSTALLED

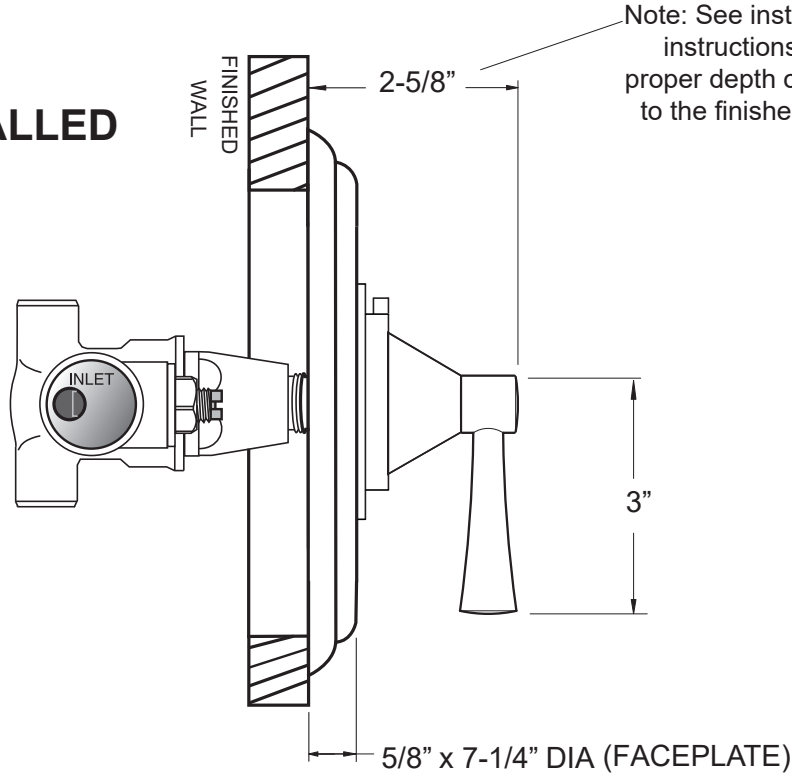

SIDE VIEW - VALVE ONLY

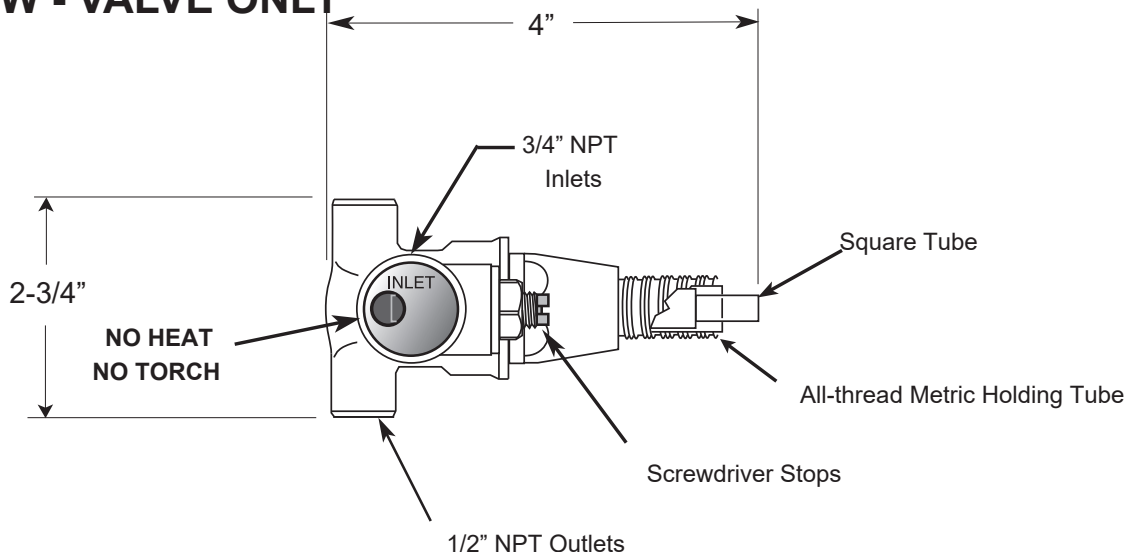

Note: Measurements are subject to change or cancellation. No responsibility is assumed for use of superseded or voided pages.