

Series 400

Pressure Balance Shower by Shower Set

1.000567

(1.000567T - Trim Only)

Charlotte Elite Handle

16 pt.

FEATURES:

- Forged brass construction
- Valve cartridge 18.30.893
- Diverter cartridge: 18.30.898
- Adjustable hot limit safety stop
- Reversible cartridge
- 4.5 GPM @ 45 PSI



FRONT VIEW

SIDE VIEW

**Note: Stem and all-thread tube will be sent with handle trim.*

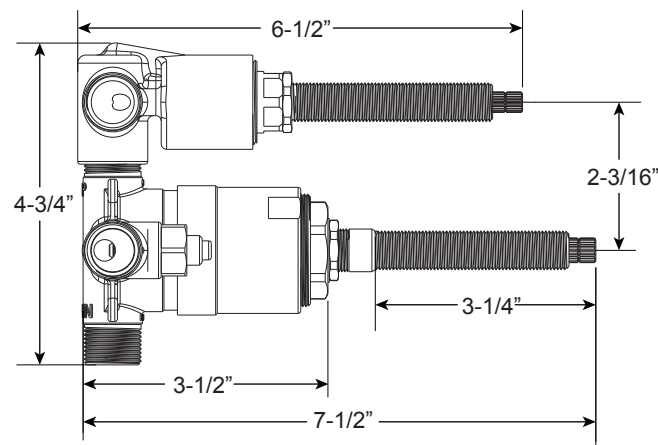

Please Note:
Must purchase the two desired shower components separately. See current catalog for shower component options.

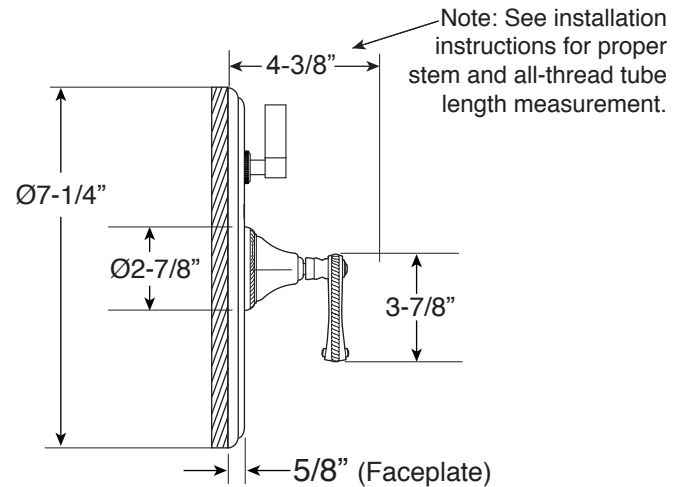

<p>* Current valve in use: Circa 4/2014 - present Contact Customer Service for Older Versions</p>	<p>** For additional information on cartridges or extension kits, see 'Rough Valving' section in current catalog.</p>
---	---

Note: Measurements are subject to change. No responsibility is assumed for use of superseded or voided pages.